



Nové funkční doplňky k vašim HPLC systémům

Marek Minárik

Watrex Praha, s.r.o., Drnovská 1112/60, 161 00 Praha 6



Watrex HPLC přístroje

od 1998

DeltaChrom™



od 2017

Streamline™

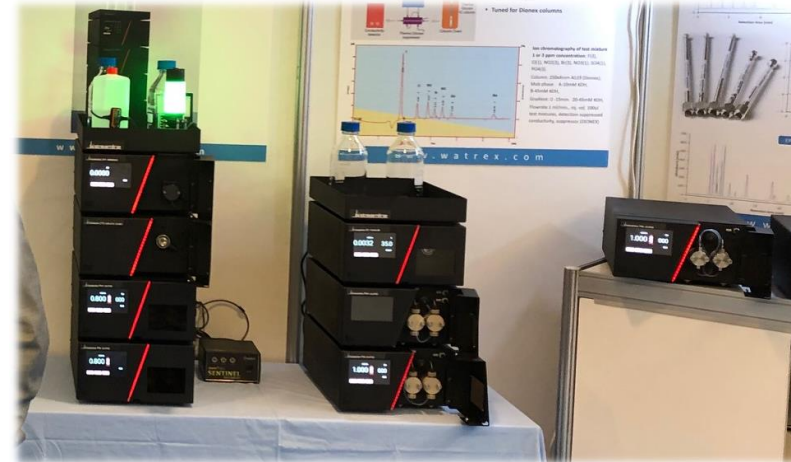

Watrex HPLC přístroje



HPLC Přístroje



Chromatografické systémy



HPLC Kolony



Separace a purifikace proteinů



HPLC spotřební materiál



Zařízení pro čištění vody

Šetřiče mobilní fáze

Motorizované ventily

Online SPE systém

Frakční kolektor

Hladinový snímač

Šetřiče mobilní fáze

Šetřiče mobilní fáze

Global Acetonitrile Market

Market Share by End Use (%)

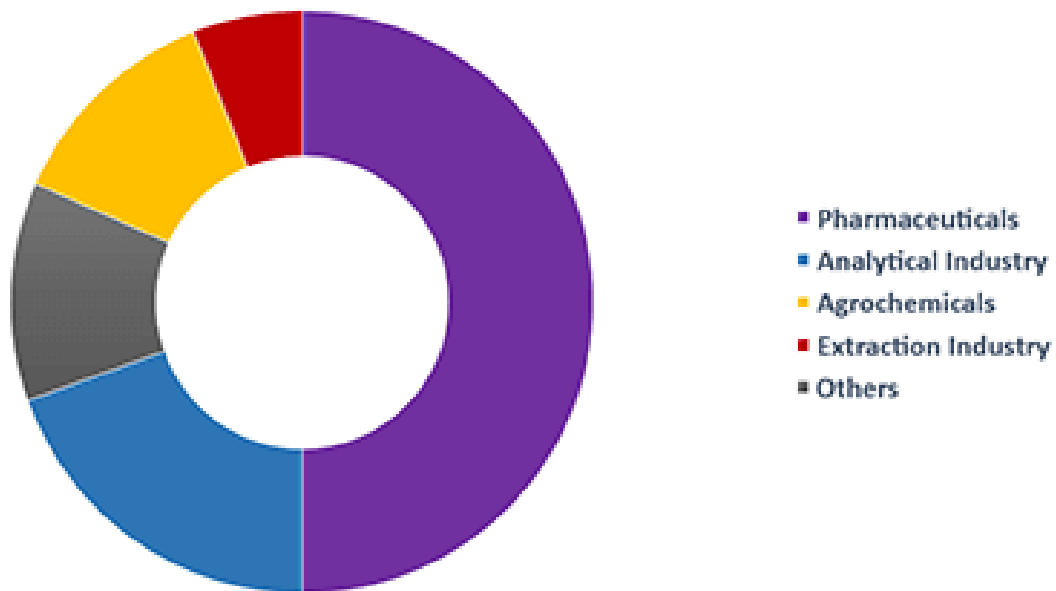

Source: www.expertmarketresearch.com



1 L ~ 5.000 Kč

Šetřiče mobilní fáze

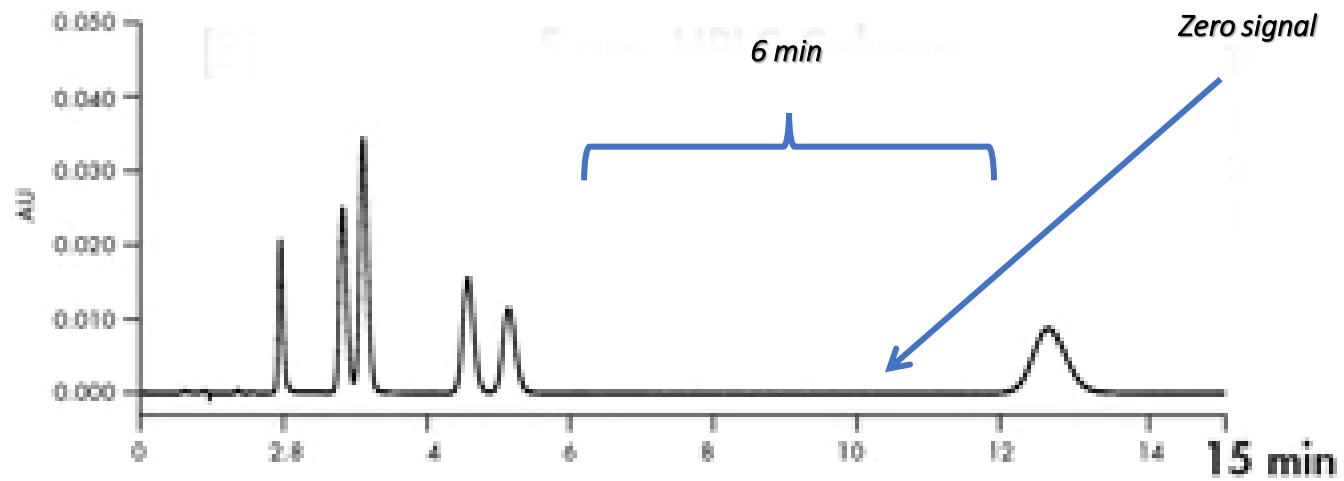

Šetříče mobilní fáze

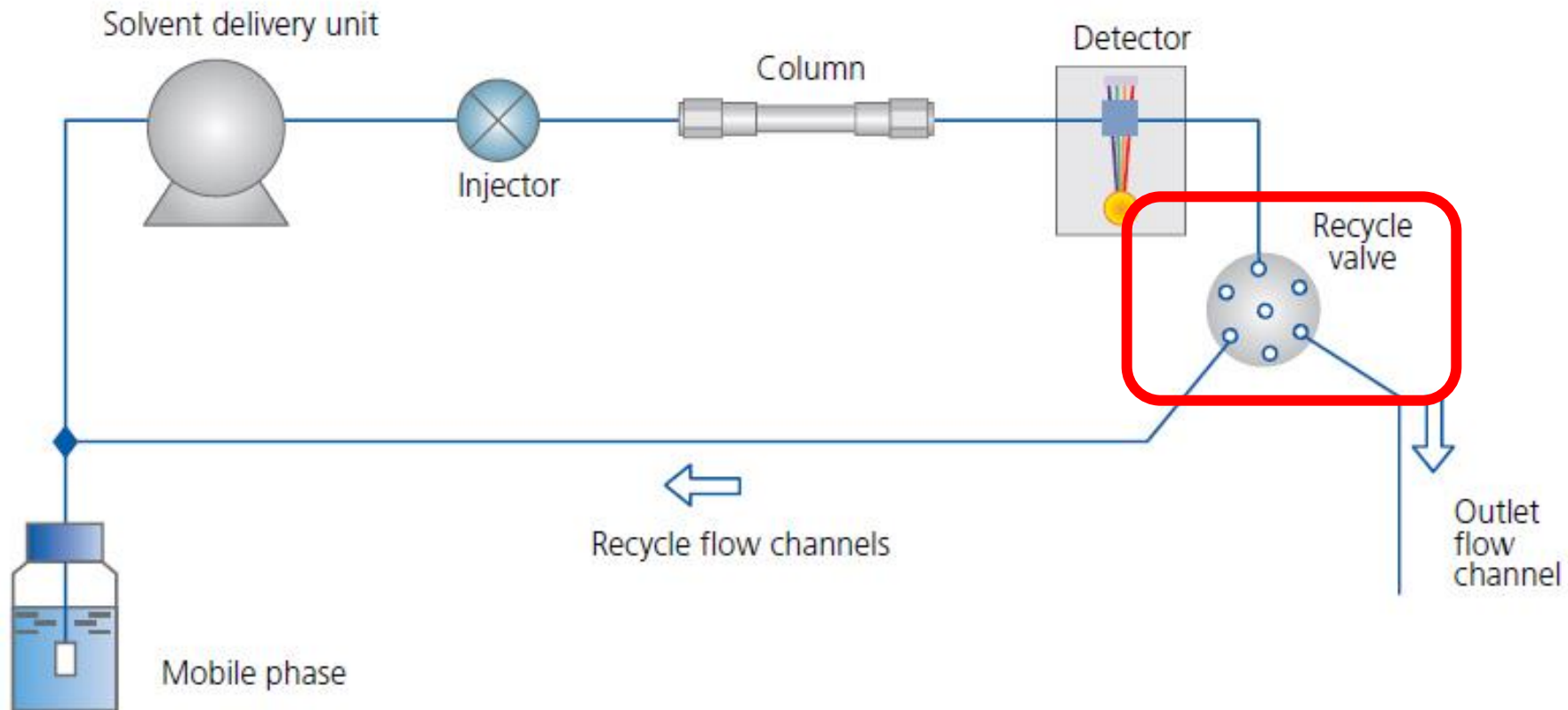

www.shimadzu.com

Šetřiče mobilní fáze

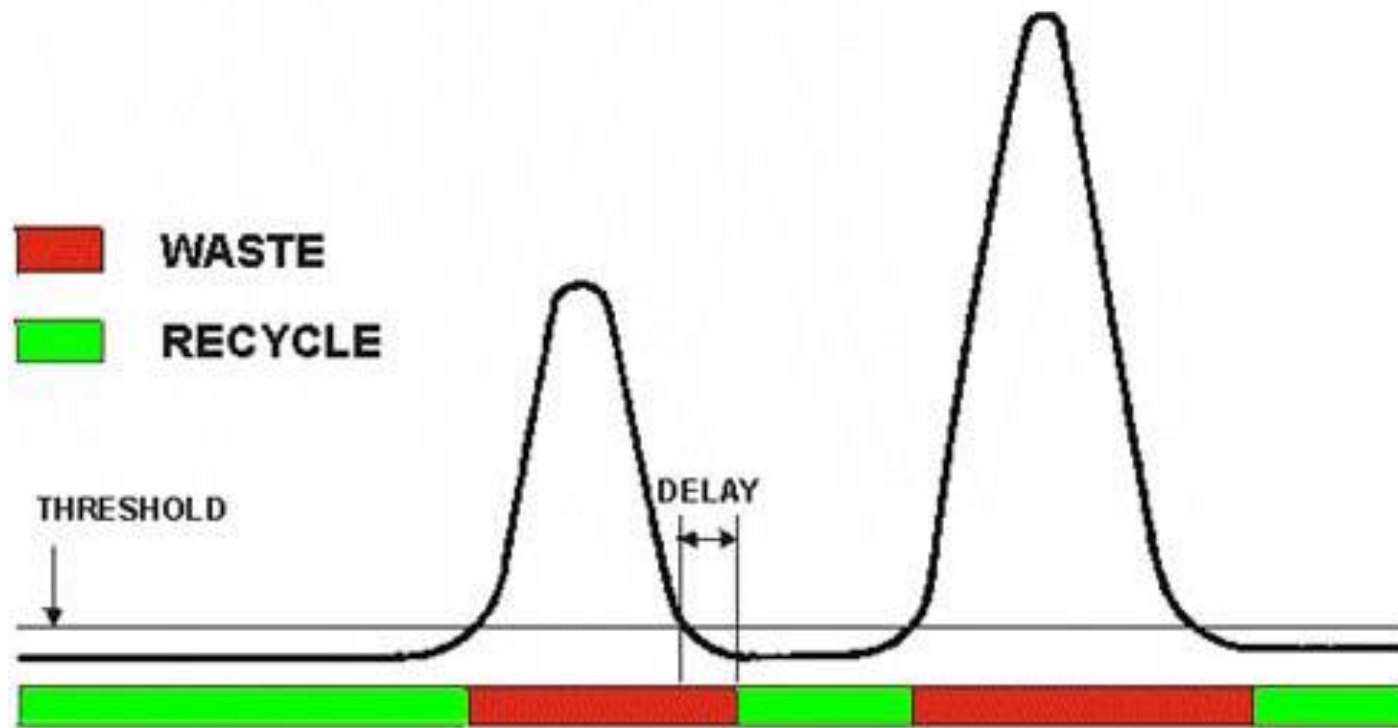

Šetřiče mobilní fáze



UFO Smart Saver™

Programovatelný
přes PC

Šetřiče mobilní fáze



SPR 110

Programovatelný
bez PC

Šetřiče mobilní fáze

Výhody recyklace mobilní fáze

Úspora mobilní fáze (finanční)

Úspora odpadů mobilní fáze (životní prostředí)

Úspora času obsluhy pro výměnu mobilní fáze



Motorizované ventily

Motorizované ventily

Multidimenzionální chromatografie

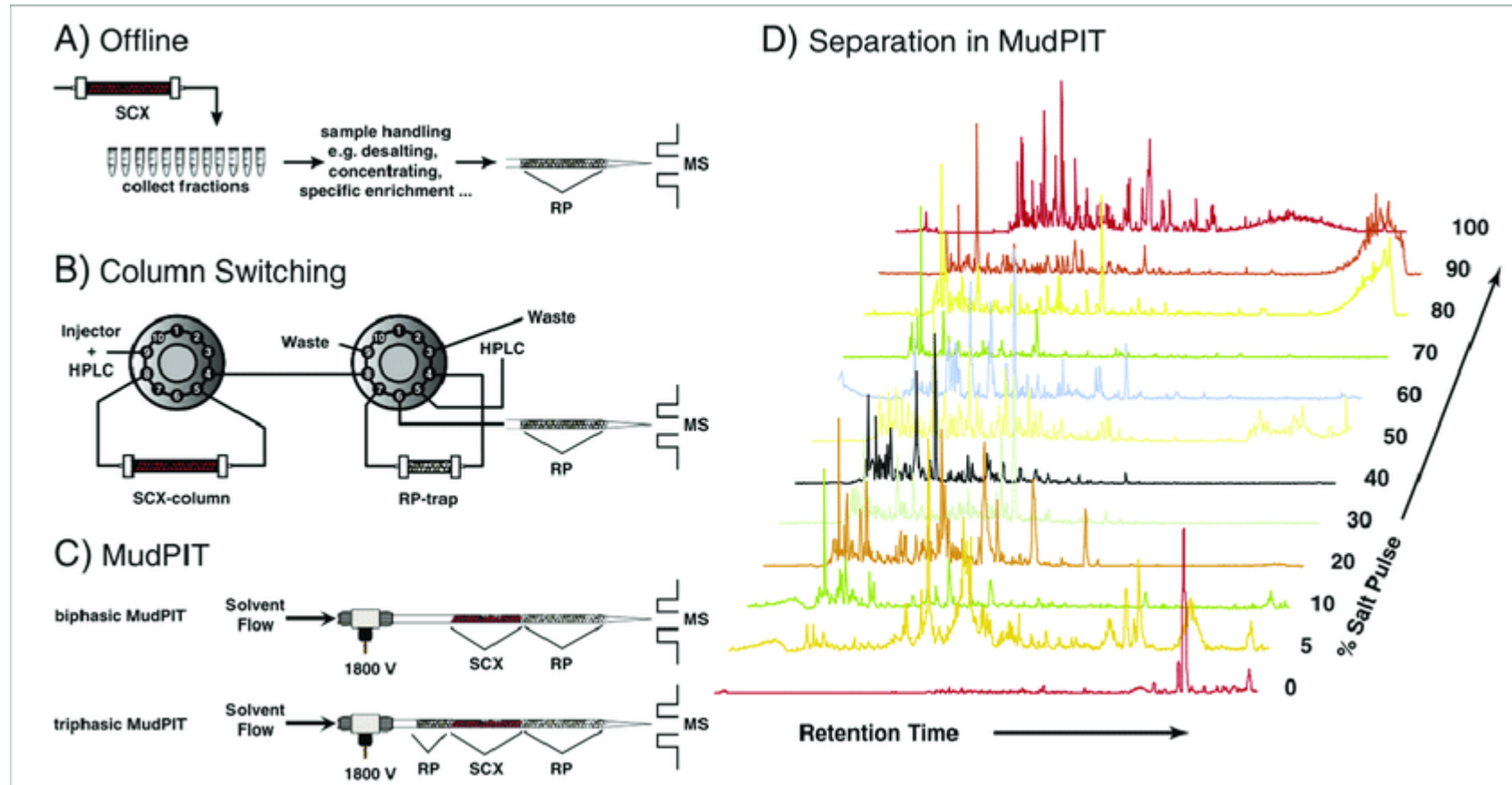

Motorizované ventily

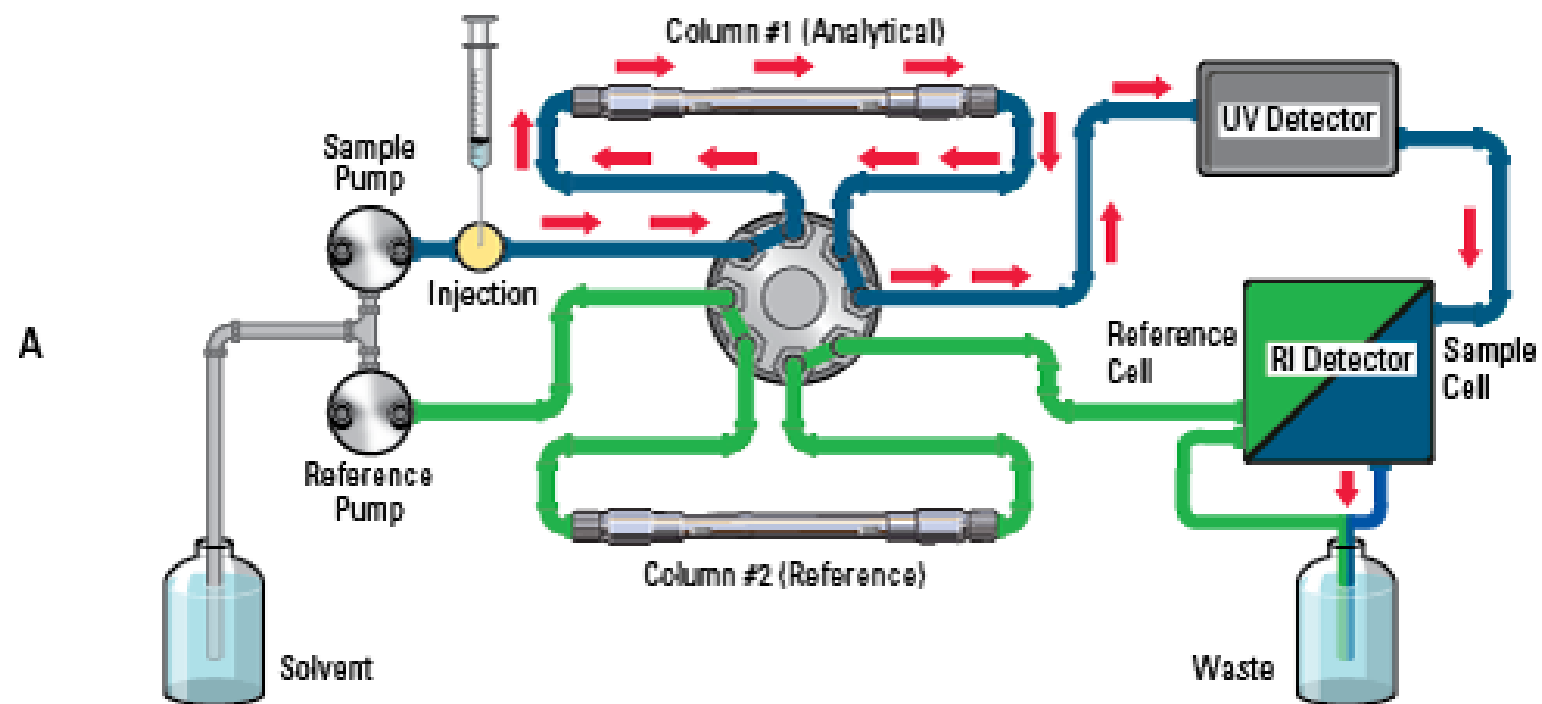

Column switching

Motorizované ventily



Motorizované ventily

VICI

RHEODYNE

Swagelok

HAMILTON

SUPERLOK

SYKAM

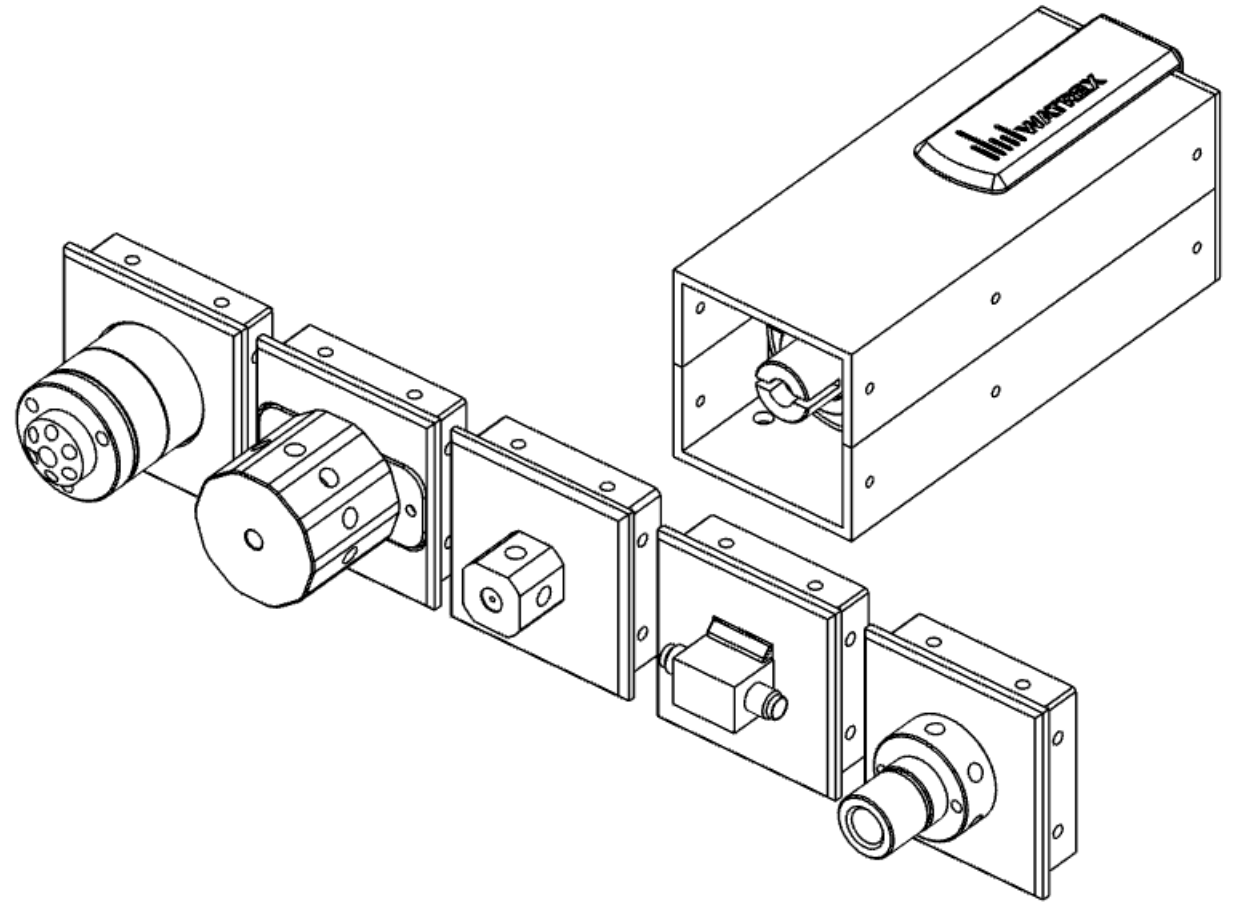

Motorizované ventily

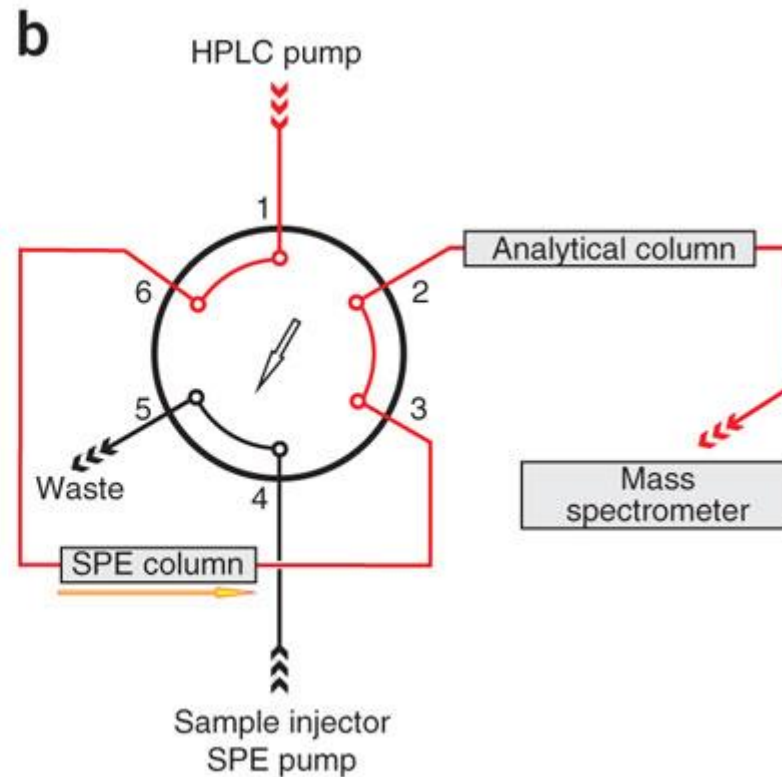
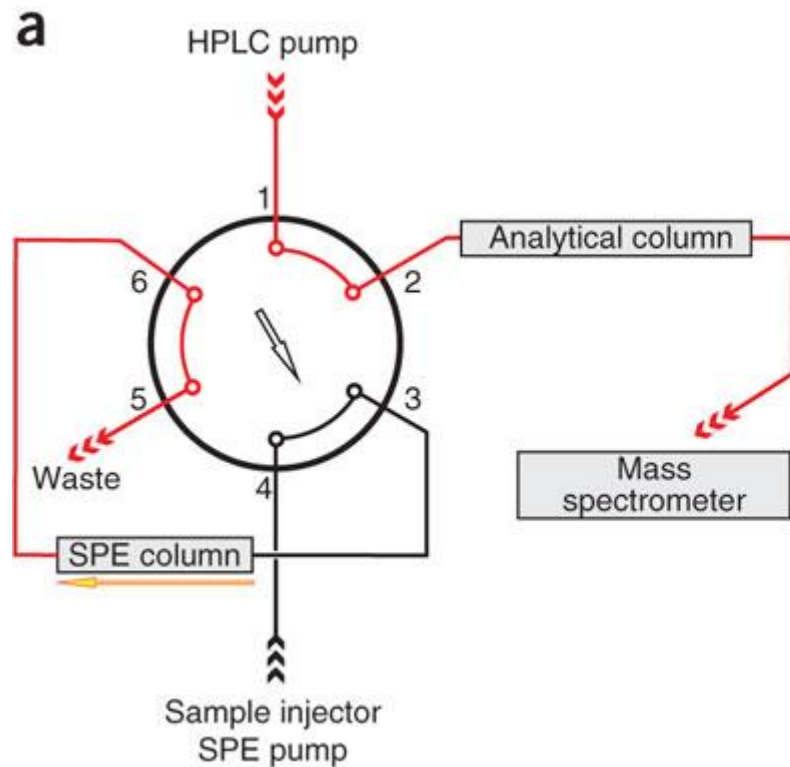

Column switching

*Integrace SPE
extrakce do systému*

Online SPE systém

Online SPE systém

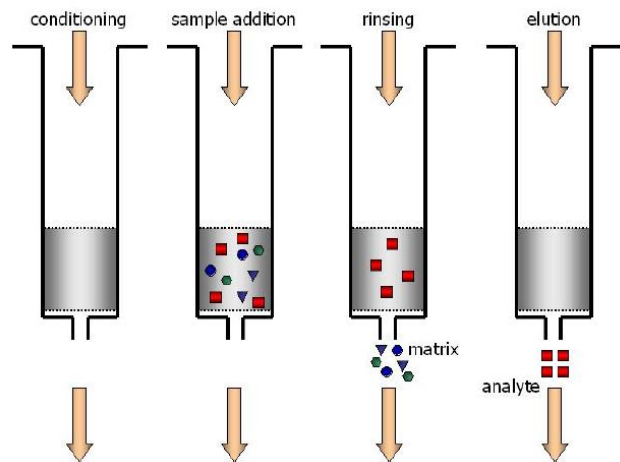

Extrakce na pevné fázi (SPE)

Aplikace:

Analýzy (odpadních) vod (PAH, PCB ...)

Klinické analýzy séra/plazmy/moči (farmaka, steroidy, opiáty ...)

Analýzy potravin (pesticidy, melamin ...)

Online SPE systém

Workflow tvoří několik základních operací: Flush, Wash, Load a Inject.

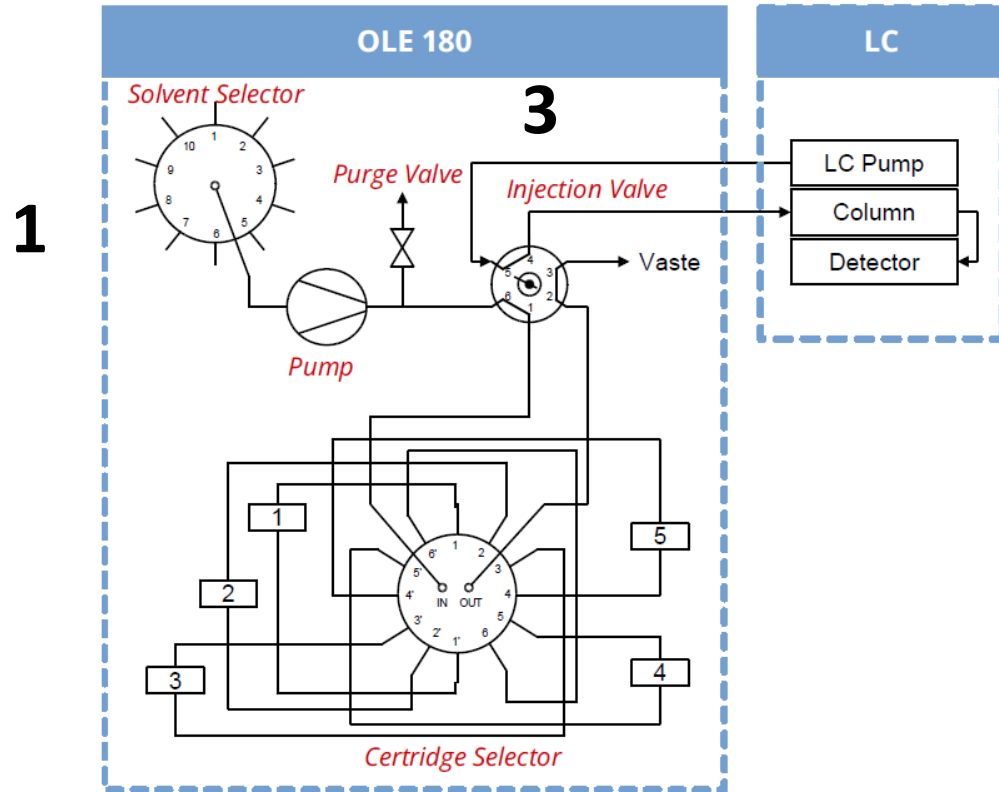

2

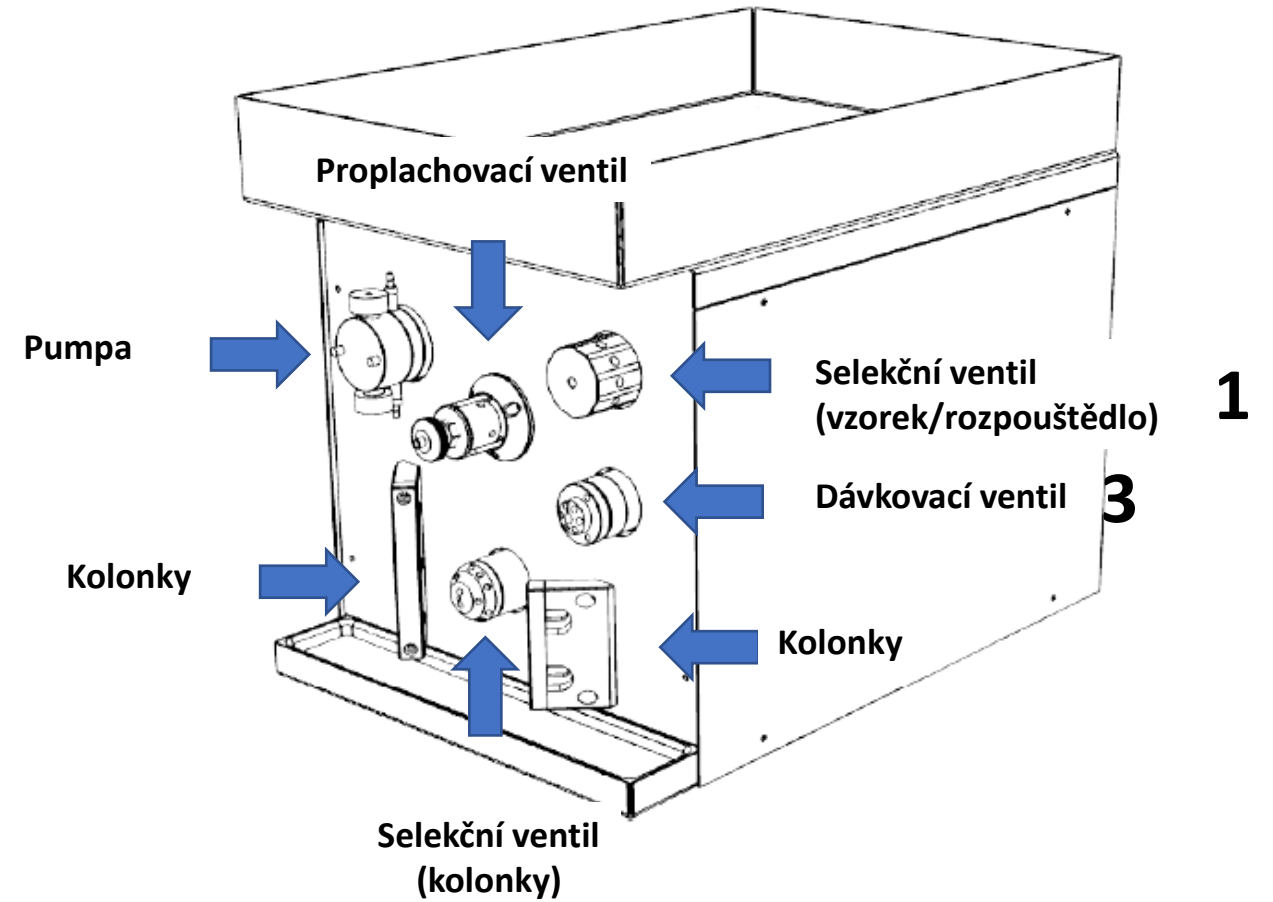

Online SPE systém

OLE 180

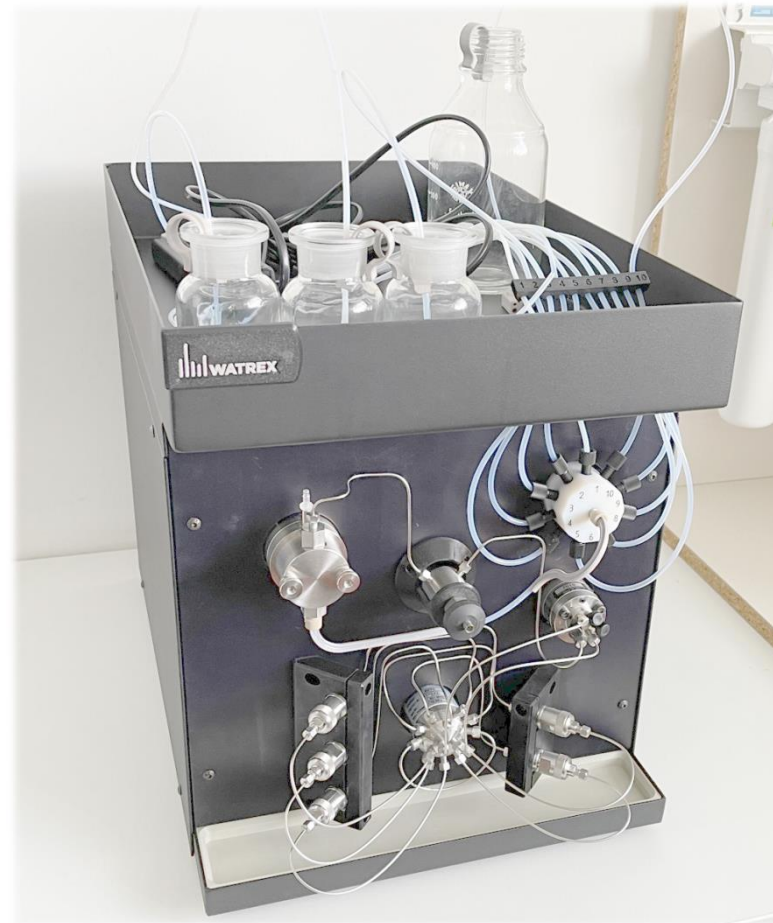

Online SPE systém



Method Setup FC_test_01 - #102; 25.4.2022 13:16:13

New Open... Save Save as... Report setup... Audit trail... Send method by e-mail... Help

Select Sampler OLE 180 (WP100242) Enabled

UNI Ruby Sampler Method

Properties

	Property	Value
1	Sample flow rate [mL/min]	2,0
2	Number of cartridges to be used	5
3	Injection time (min.)	0,1
4	Number of samples per cartridge	10

AS Status Not Ready (Method has not been sent) AS Status...

Event Table AS Measurement Acquisition Integration Calculation Advanced

OK Cancel Send Method

Online SPE systém



DEV - Device Monitor

File Control View Window Help

DEMO Ready ✓

OLE 180 (WP100242) Idle ✓

	Property	Value
1	Ready State	Ready
2	Solvent selector position	10
3	Sample flow rate	OFF
4	Injector position	1
5	Cartridge selector position	6
6	Cartridge state	cartridge: 1, injection: 9 / 10
7		Reset Counter
8	Lines to be purged	1-10
9		Purge Lines

For help press F1.

Frakční kolektor

Frakční kolektor

FC1



Frakční kolektor

Time-based

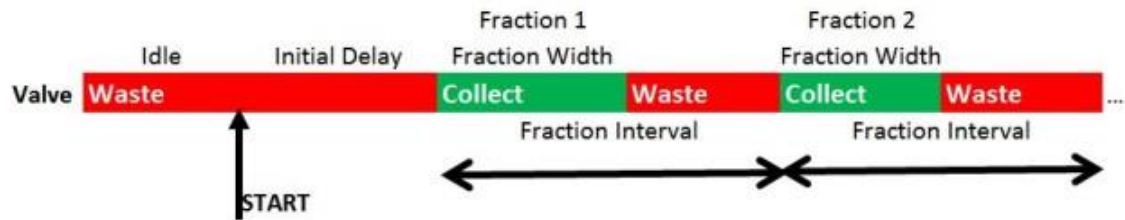

Signal threshold-based

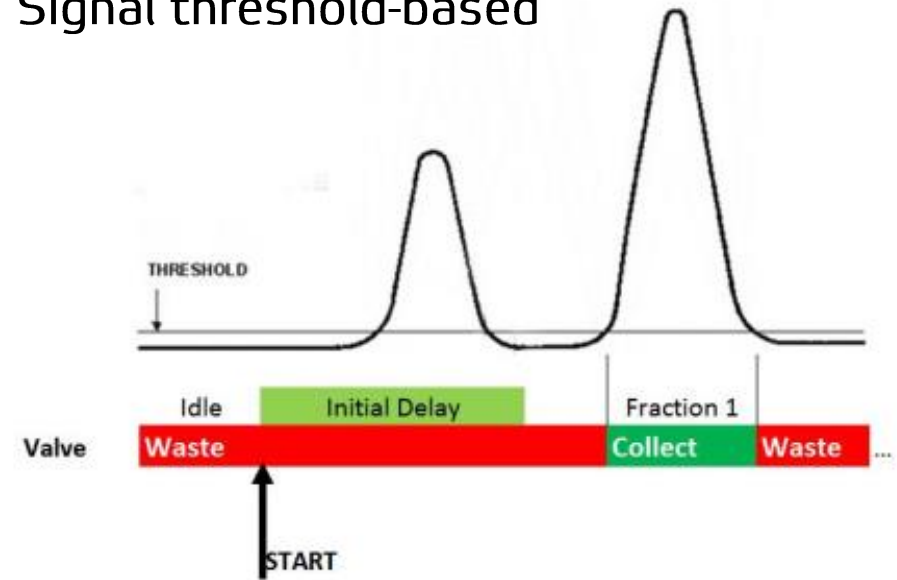

Frakční kolektor

Diverter valve

Pohyblivý blízko výstupu



Nízký mrtvý objem



Přesná frakcionace

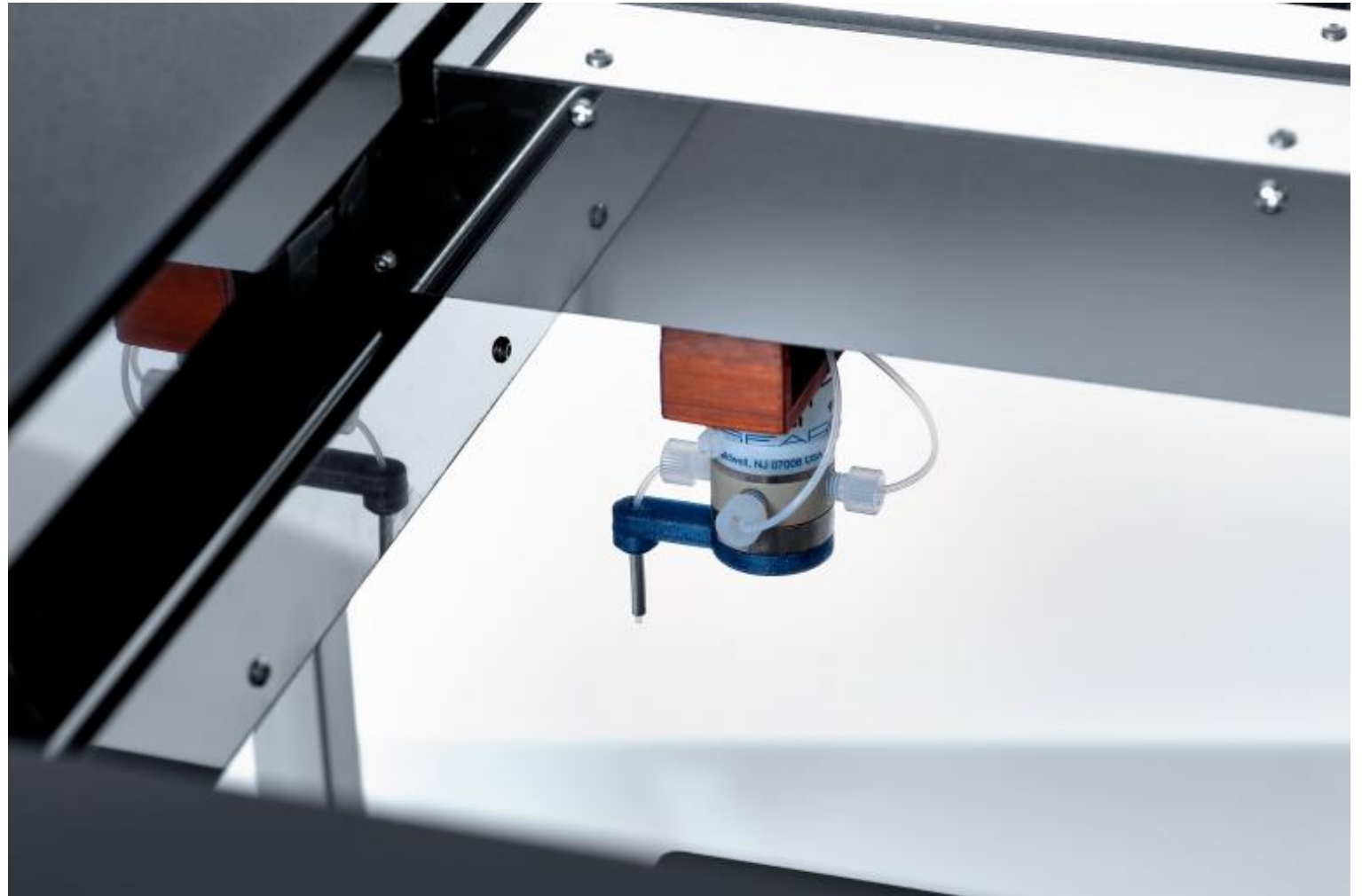

Frakční kolektor



Možnost sběru do mikrotitračních destiček s chlazením

Liquid sensor

Liquid sensor



Liquid sensor



Děkuji za pozornost



Watrex Praha, s.r.o.
Drnovská 1112/60
161 00 Praha 6 – Ruzyně

www.watrex.com

