

# Avoiding Cross Talk

In 96-well Based Sample Preparation

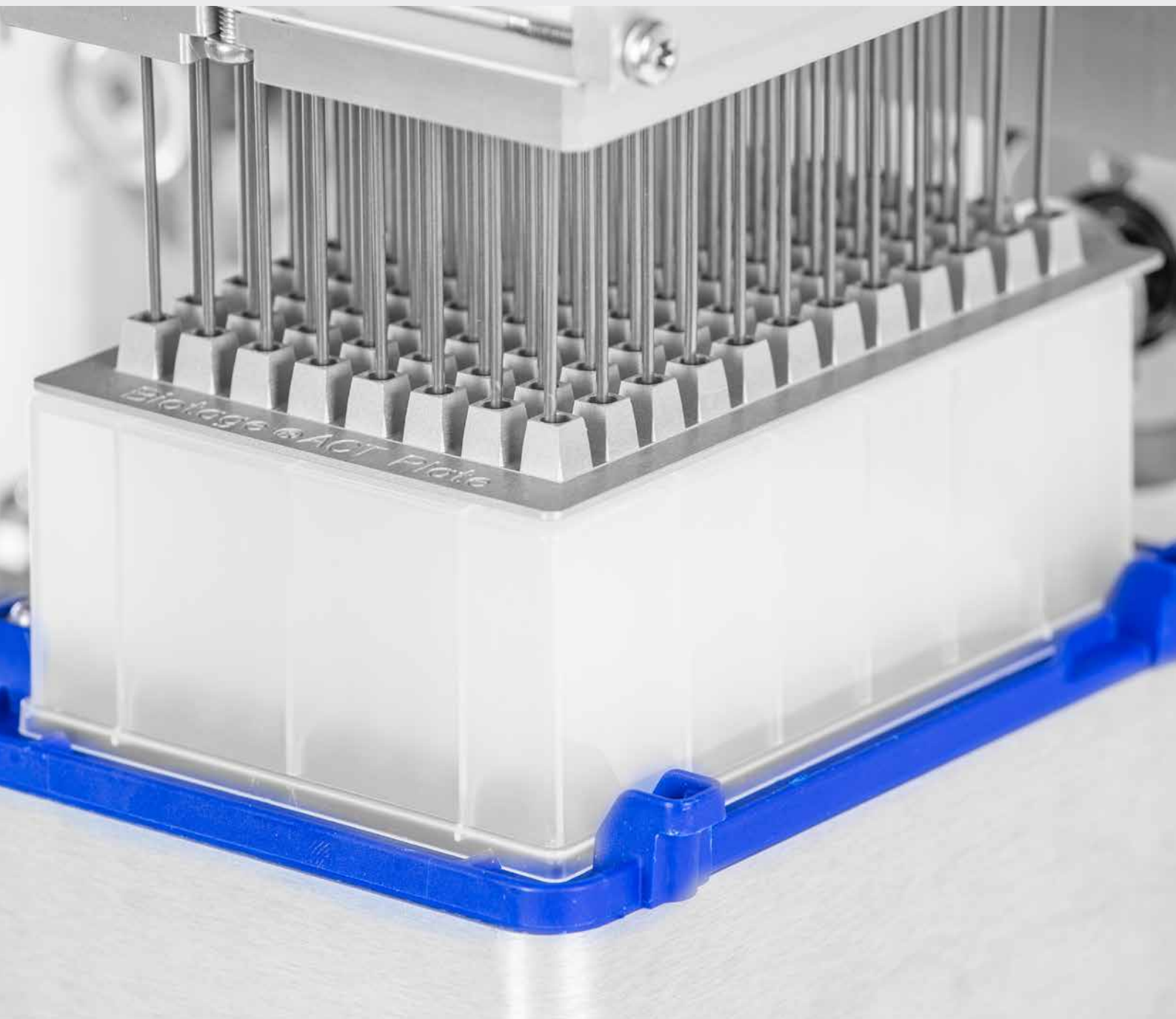

# Avoiding Cross Talk

## CONTENTS

- 1 Introduction
- 2 Extraction and Collection Plate Design  
Correct Penetration of Luer Tips (Plate Outlet Nozzles) into Collection Plate Wells
- 3 Sample Processing  
Automated Sample Processing:  
Biotage® Extrahera™ Automation system  
Manual Positive Pressure Processing:  
Biotage® PRESSURE+ 96  
Manual Vacuum Processing: Biotage® VacMaster™-96
- 5 Evaporation  
Biotage® ACT Plate Adapter  
Solvent Volume Optimization  
Devolatilization of Volatile Analytes
- 7 Sample Mixing
- 8 Appendix  
Controlling Evaporative Crosstalk in Urine Specimens with High Drug Concentrations





## Introduction

In all areas of clinical laboratory testing, it is vital to ensure proper quality measures are in place to avoid or eliminate carryover between samples, and reduce the risk of false positive results. One area that is often overlooked is the sample preparation stage.

The transition from individual column to 96-well based, high-throughput sample preparation methods is one of many examples of the progress in clinical laboratory testing. Samples can be processed more rapidly and many automated systems have been developed for processing 96-well plates. However, small sample volumes with widely varying unknown analyte

concentrations and the close layout of 96-well plates can increase the likelihood of false-positive results for wells in close proximity to wells with significantly elevated analyte concentrations.

**This guide aims to describe simple practical strategies, hints and tips designed to mitigate or avoid cross-well contamination or 'cross talk' in high throughput 96-well based sample preparation techniques.**

All aspects of the sample preparation procedure should be considered when trying to avoid or eliminate the potential for cross talk. Sample preparation hardware (e.g. extraction and collection plates), processing equipment and conditions (including evaporation) and method parameters (e.g. solvents and volumes) are important aspects to optimize.

# Extraction and Collection Plate Design

## Correct Penetration of Luer Tips (Plate Outlet Nozzles) into Collection Plate Wells

Various 96-well extraction plate styles (incorporating SPE, SLE, protein precipitation and other sample preparation techniques) are commercially available, and differences in their design can play a significant role in the degree of potential cross-well contamination<sup>1</sup>.

Extraction plates can differ in both the length of the Luer tip, and the distance between the tip of the Luer and the plate sealing edge (where the plate rests during processing, see **Figure 1**), thus affecting the penetration of the outlet nozzle into the collection plate during processing.

During sample preparation procedures, the extraction solvent flows through the wells (under vacuum, gravity or positive pressure) and exits through the Luer. Under certain conditions, a small burst of fine droplets released as an aerosol can form as the well empties (sputtering). This risk is increased when using solvents with lower surface tension (or more volatile solvents), and may be exacerbated when using vacuum compared to positive pressure for processing the plate.

Whatever the choice of processing equipment (automated or manual, positive pressure or vacuum based) it is important to ensure that there is sufficient penetration of the Luer tips into the wells of the collection plate.

Biotage's range of 96-well extraction plates (including base plates that can hold up to 96 individual tabless 1 mL columns), collection plates and processing equipment (Biotage® Extrahera™ SLE and SPE Automation System,

Biotage® Pressure-96 Positive Pressure Manifold and Biotage® VacMaster™-96 Vacuum Manifold) work together to ensure the correct fit and trouble free sample processing (see Sample Processing section).

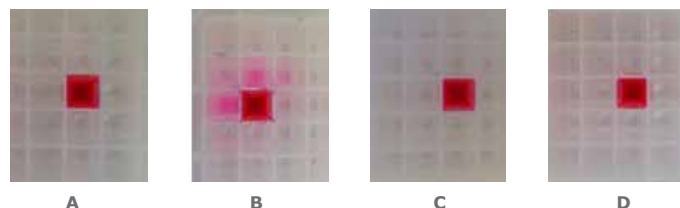

**Figure 2.** Impact of optimized Luer tip penetration on adjacent well contamination when processing SPE plates under different conditions. A: Vacuum (VacMaster™-96) with optimized spacer. B: Vacuum (VacMaster™-96) with non-optimized spacer. C: Positive pressure (Biotage® Extrahera™). D: Positive pressure (Biotage® Pressure + 96).

Solvent: MeOH containing dye as marker.

Luer tip length and penetration depth into collection plate are most significant parameters for contamination reduction, but other parameters such as the diameter of the Luer opening may also affect performance under some conditions.

### Other aspects of collection plate design to consider

- » Always use a collection plate that has sufficient volume to contain the required volume of elution solvent, so that wells do not become over full
- » If mixing the sample in a 96-well plate, ensure sufficient headspace to accommodate liquid displacement

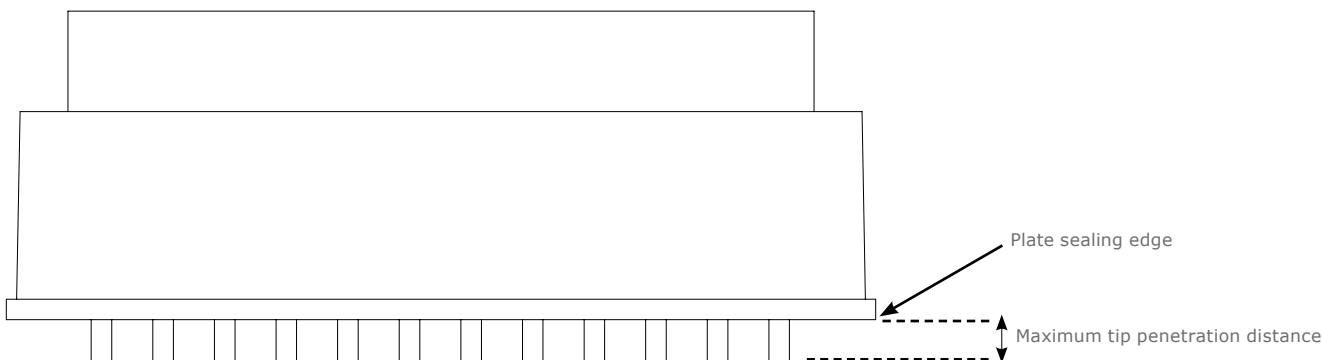

**Figure 1.** Profile of a 96-well extraction plate

# Sample Processing

## Positive Pressure vs. Vacuum Processing

Processing 96-well plates using positive pressure rather than vacuum can be beneficial in reducing the risk of cross talk due to the reduced risk of aerosol formation (sputtering) during solvent elution. Biotage offers a range of processing systems, both automated and manual, which are optimized for 96-well processing.

### Automated Sample Processing: Biotage® Extrahera™ Automation system

The Extrahera™ instrument can be used to process 96- and 48-well extraction plates, along with 96 individual 1 mL tabless columns. Additionally the system is capable of processing 24 x 1, 3 or 6 mL columns held in a standard microtitre plate footprint. The instrument incorporates a number of features designed to eliminate sample cross contamination throughout the sample preparation method.

- » The positive pressure system minimizes sputtering (or aerosol formation) by controlling processing flow so there is no significant increase in solvent flow rate as the well empties. The maximum flow restriction is in the positive pressure processing head to ensure consistent flow rates, between wells or columns during processing. In addition, built in maximum capacity volumes can be assigned to every consumable which will minimise the chances of contaminating the sealing mat on the positive pressure head by over filling when loading sample.



- » Before each operation in the method, the carousel moves the flow through plate (for directing waste) and the collection plate (or tube rack if processing columns) into the correct position. When located, the plate lifter raises the collection plate or rack to a position directly beneath the extraction plate or column, and ensures correct Luer/well penetration.
- » Waste is directed via the flow through plate to an external collection reservoir. The flow through plate prevents droplets from contaminating adjacent Luers. The flow through plate, by design, when used in combination with the lifter eliminates Luer to Luer contamination on well-plates or columns. During elution, contamination of adjacent collection wells or tubes from splashing/sputtering etc. is also eliminated with the flow through plate.
- » Pipette tip aspirate and dispense heights can be tuned for every consumable on the system and as a consequence safe reagent pipette tip reuse is possible without the risk of contamination.
- » It is impossible for the system to transfer from the sample plate/tube to the incorrect well/column during consumable loading, ensuring sample traceability, and it is impossible to reuse a pipette tip following sample dispensation on a subsequent different sample.







### Manual Positive Pressure Processing: Biotage® PRESSURE+ 96

Biotage® Pressure + 96 manifolds deliver consistent positive pressure, parallel processing for 96-well plates. The systems utilize a uniform flow of positive pressure to move both high and low viscosity liquids through 96-well plates and up to 96 tabless 1 mL columns held in a specially designed base plate.

#### 96-well Plates

During processing using the Pressure + 96, the extraction plate is positioned directly on top of the collection plate, ensuring maximum Luer tip penetration.

#### Tabless 1 mL Columns

The base plate holds the columns securely on top of the collection plate and ensures there is no lateral movement. It is designed to allow maximum possible Luer penetration into the collection plate.



96 x 1 mL tabless columns on Biotage® Pressure+ 96

### Manual Vacuum Processing: Biotage® VacMaster™-96

The VacMaster-96 manifold is designed to allow correct penetration of the Luer tips of extraction plates into collection plates during processing. Spacers are used to accommodate the various designs of extraction and collection plate. These do not cause any vacuum loss but ensure Luer tips are positioned correctly.

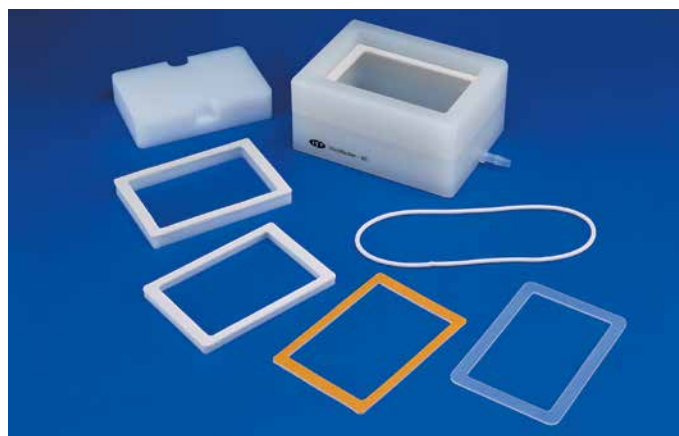

Biotage® VacMaster™-96 spacer options for extraction and collection plates to allow Luer tip position optimization

#### Collection Plate Compatibility

Collection plates from various suppliers can vary in height. Spacer inserts are available for Biotage® VacMaster™-96 to allow different designs to be used without compromise of Luer penetration.

#### Tabless Column Base Plate

The Biotage tabless column base plate (holds up to 96 tabless 1 mL columns, unused positions sealed with sealing tape) is also designed to provide adequate Luer penetration without the need for spacers when used on the VacMaster-96.



# Evaporation

Sample extracts often require evaporation following commonly used sample preparation techniques, for example to reduce volume/increase concentration, or to exchange a solvent for one more compatible with the subsequent analytical technique. Extracts are generally contained in a 96-well collection plate during evaporation and processed under a controlled flow of air or nitrogen. There are a number of strategies that can be utilized to avoid/eliminate cross talk linked to evaporation.

## Biotage® ACT Plate Adapter

“Hotspot” carryover is a phenomenon observed in assays using a forced evaporation with commercially available equipment. During the evaporation stage, a proportional amount of analytes present in an extracted sample can contaminate surrounding wells by being carried with the volatilized solvent (see **Figure 3**). When analyte concentration in the “hotspot” well is considerably higher than the analyte concentration in the surrounding wells it has the potential to cause a clinically significant change in quantitation of the samples in the surrounding wells and thus potentially disastrous clinical implications.

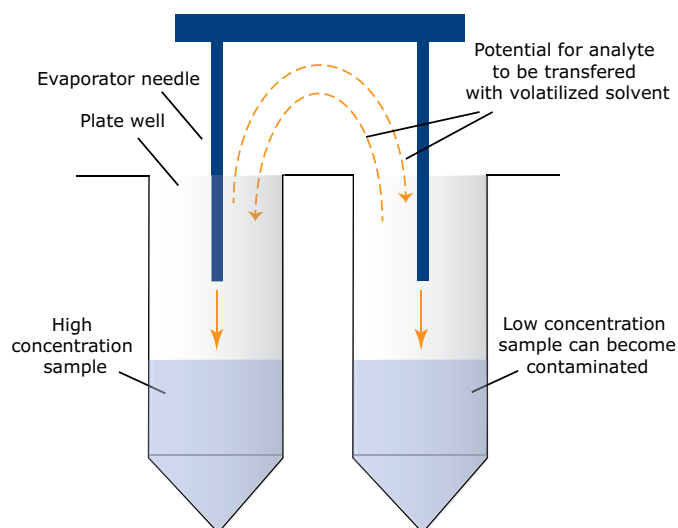

**Figure 3.** Mechanism for ‘hot spot’ cross talk during evaporation.

Biotage® ACT (Anti-Cross Talk) Plate Adapter (part number 414355SP) is designed to fit on top of the 96-well collection plate. The plate adapter ‘chimneys’ direct the gas flow into the wells. Evaporated gases are directed away from adjacent sample wells, eddies are reduced, and the adapter reduces the open surface area of the top of the wells, eliminating the likelihood that volatilized solvent containing analyte can re-enter and contaminate adjacent wells.

The plate adapter can be incorporated into existing assays without the need for changing any other aspects of the method.

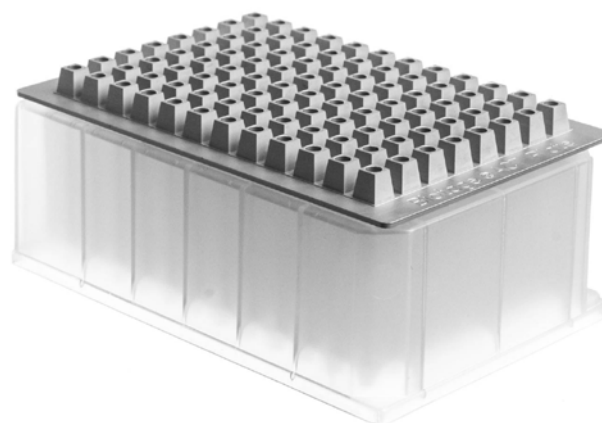

Biotage® ACT Plate adapter in position on 2 mL collection plate



Evaporation on TurboVap® 96 Dual using Biotage® ACT Plate Adapter.

To evaluate the effect of Biotage® ACT Plate Adapter on evaporation related cross talk, the following experimental design was used:

A single well (position C<sub>3</sub>) of a 96-well plate was spiked at a very high concentration with marker compound (amphetamine, 2 µg/mL) reflecting a high level positive sample. Surrounding wells were spiked at the method LOQ. The concentration of amphetamine in the surrounding wells was measured using LC-MS/MS following evaporation with and without the use of Biotage® ACT plate adapter.

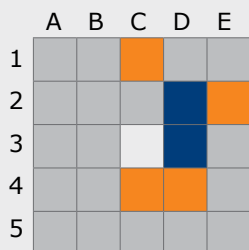

**Figure 4a.**  
Map of amphetamine concentration after evaporation with no plate adapter used.

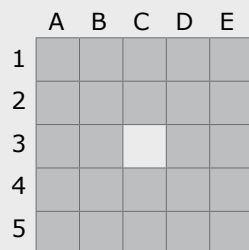

**Figure 4b.**  
Map of amphetamine concentration after evaporation using the plate adapter.

#### Key

- White (position C<sub>3</sub>) = high level spike
- Dark Blue = amphetamine concentration measured at >10 x LOQ reflecting gross cross contamination
- Orange = amphetamine concentration measured at >2 x LOQ reflecting low level cross contamination
- Grey = amphetamine concentration measured at LOQ reflecting no cross contamination

In the data presented above, samples evaporated using Biotage® ACT Plate Adapter display complete absence of cross talk. Conversely samples evaporated without Biotage® ACT Plate Adapter show false positive results with concentrations > 10 times the LOQ.

## Solvent Volume Optimization

When using standard 'square well' collection plates certain solvents (e.g. methanol) can 'creep' up the corners of the collection plate during evaporation, and potentially cause well to well contamination. This is more likely when the solvent volume exceeds the recommended volume for that particular plate; or when excessive evaporation gas flow rates are used.

We recommend the following maximum solvent volumes for Biotage square well collection plates.

Nominal well volume	Recommended maximum solvent volume
1 mL	0.75 mL
2 mL	1.5 mL

### Alternative Design: Round Well Plates

Collection plates with a circular well cross section (p/n 121-5213) may be useful in avoiding the solvent creep effect.

## Devolatilization of Volatile Analytes

A technique that is often used to prevent low recovery of volatile analytes during evaporation procedures may also be used to minimize cross talk. For example, the addition of HCl or tartrate solution to some analyte suites to make the less volatile salt form can reduce the possibility of cross talk.

Alternatively, the addition of a keeper solvent (eg glycol) to prevent complete evaporation may of more volatile extraction solvents may also be beneficial.

### Other Aspects of Evaporation to Consider

- » Check that evaporator needles are not too close to the surface of the solvent
- » Ensure that the evaporating gas flow rate is not excessive.



# Sample Mixing

It is common practice to mix samples and/or reconstitute samples after evaporation in 96-well collection plates prior to LC-MS/MS analysis. Mixing speeds and solvent fill volumes should be optimized for the design of collection plate used.

We recommend the following maximum solvent volumes for Biotage collection plates

Nominal Well Volume / Design	Recommended Maximum Solvent Volume
1 mL square	0.5 mL
2 mL square	1.5 mL
2 mL round	1.7 mL

If maximum solvent fill volumes are exceeded, cross contamination of adjacent wells may occur. This is illustrated below using various collection plate designs containing a dye to track cross contamination.



**Figure 5a.** 0.5 and 0.75 mL volumes mixed in a 1 mL/well nominal volume square collection plate (Vortex Genie, setting 3) showing potential cross contamination when max fill volume is exceeded.



**Figure 5b.** 1.5 and 1.75 mL volumes mixed in a 2 mL/well nominal volume square collection plate (Vortex Genie, setting 3) showing potential cross contamination when max fill volume is exceeded.



**Figure 5c.** 1.7 and 1.8 mL volumes mixed in a 2 mL/well nominal volume round collection plate (Vortex Genie, setting 3) showing potential cross contamination when max fill volume is exceeded.

## References

1. L. Marshall et al., *The Effects of Plate Type on the Prevalence of Cross-well Contamination While Using Automated Solid Phase Extraction Instruments*. Poster presented at Pittcon 2011.

# Controlling Evaporative Crosstalk in Urine Specimens with High Drug Concentrations

Stephanie J. Marin, Jeremy Smith, Mario Merida,  
Biotage, 10430 Harris Oaks Blvd., Suite C, Charlotte North Carolina 28269, USA.

## Introduction

Evaporative crosstalk is well-to-well cross contamination during extract evaporation after SLE or SPE extraction in a 96 well plate. It is often observed with volatile analytes like methamphetamine and amphetamine, but it can also occur with other drugs and metabolites when some urine samples have very high analyte concentrations. The Biotage<sup>®</sup> ACT Plate Adapter does help to control evaporative crosstalk, however in samples with very high concentrations, additional measures in addition to the ACT Plate Adapter should be considered.

Urine specimens analyzed by LC-MS/MS with analyte concentrations in excess of 100,000 ng/mL have been observed in some laboratories. Controlling crosstalk for these samples with such high concentrations presents a special challenge and is particularly difficult for volatile analytes like sympathomimetic amines. Adding hydrochloric acid in methanol (HCl in MeOH) to form chloride salts helps to keep analytes like methamphetamine and amphetamine in solution during evaporation. We conducted multiple experiments in our Charlotte applications lab to determine how to control crosstalk in these high concentration samples using the ACT Plate Adapter and HCl in MeOH.

## Methods and Materials

Standards were purchased from Cerilliant (Round Rock, TX). Solvents and other reagents were purchased from Reagents (Charlotte, NC). Urine was collected from healthy volunteers. Samples were extracted using 400 µL ISOLUTE<sup>®</sup> SLE+ 96 well plates (Biotage part number 820-0400-P01), and eluent was collected in 2 mL square collection plates (Biotage part number 121-5203) and evaporated using a Biotage<sup>®</sup> SPE Dry at 40 °C upper, 60 °C lower, and gas flows 40 upper and 30 lower<sup>(1)</sup>.

Experiments were designed to evaluate crosstalk under different conditions. Eight different drugs and metabolites were evaluated: amphetamine, methamphetamine, MDA, MDMA, MDEA, benzoylecgonine, morphine and hydromorphone. Extractions were set up with an extraction blank and urine calibrators populating the first column. Two or three spiked urine specimens at concentrations between 50,000 and 100,000 ng/mL were placed in different areas of the plate. The rest of the plate was populated with samples of drug free urine. Samples were analyzed using a Shimadzu Nexera UPLC and a Sciex 5500 triple quadrupole mass spectrometer. Experiments were done with and without the Biotage<sup>®</sup> ACT Plate Adapter

(part number 414355SP), and with different concentrations of HCl in MeOH.

Briefly, each extracted sample was 150 µL urine treated with 165 µL of a master mix designed to be consistent with reagents added for enzyme hydrolysis: pH7 phosphate buffer, methanol (to mimic addition of internal standard solution) and water. Samples were not hydrolyzed. Each sample was pretreated with 300 µL of 0.1% ammonium hydroxide. Next, 400 µL of each treated sample was loaded onto individual wells of the 400 µL ISOLUTE SLE+ plate and extracted using the standard SLE+ protocol<sup>(2)</sup>. Samples were eluted with 2 x 600 µL of 90:10 dichloromethane:2-propanol. The elution solvent was evaporated using a Biotage SPE Dry and reconstituted and analyzed following the LC-MS/MS method in Biotage document PPS443<sup>(3)</sup>.

## Results

Values in Figures 1-4 are concentrations in ng/mL. Yellow are spiked samples. Pink are concentrations >20 ng/mL in negative samples. Figures 1 and 2 only had methamphetamine and amphetamine spiked in wells C4 and F7. Initial experiments showed that there no evaporative crosstalk observed for benzoylecgonine, morphine or hydromorphone with or without the ACT Plate Adapter and the addition of 10 µL of 1 mM HCl in methanol. Some crosstalk was detected in drug free urine samples adjacent to a spiked sample for MDA, MDEA and MDMA but was reduced to <5 ng/mL with the ACT Plate Adapter. Evaporative crosstalk with concentrations in drug free wells between 2 and 200 ng/mL were observed for methamphetamine and amphetamine without the ACT Plate Adapter (Figure 1). This was reduced to 1 to 100 ng/mL when the ACT Plate Adapter was used (Figure 2), but this was still too high for many clinical and forensic assays. Further work focused on reducing crosstalk for methamphetamine and amphetamine only.

Next, the concentration of HCl in MeOH was increased. Extractions were performed and either 10 µL of 0.25% HCl in MeOH (Figure 3) or 10 µL of 0.5% HCl in MeOH (Figure 4) were added to separate extracted plates prior to evaporation. Some crosstalk was still observed at both concentrations, but was reduced to <30 ng/mL for both analytes with 10 µL of 0.5% HCl in MeOH and the ACT Plate Adapter. The SAMHSA confirmation cutoff for methamphetamine and amphetamine in urine is 250 ng/mL<sup>(4)</sup>.

amphetamine												
	1	2	3	4	5	6	7	8	9	10	11	12
A	blank									0		
B	1		5	11						0		0
C	5	36	110	100K			3			100K		1
D	10	47	10		2	3						0
E	50	6	4	7	12	16	10	4		1		1
F	100	51	32	31	53	194	50K	5	5	1		
G	500	31	58	26	28	65	34	6				1
H	1000	7	5	4	4	7	4	3			1	2

methamphetamine												
	1	2	3	4	5	6	7	8	9	10	11	12
A	blank	1	1	2	1	1	1	1				
B	1	3	5	5	0	2	1					
C	5	23	112	100K	1	2	1			100K		
D	10	51	10	2	2	4	2	1	1			
E	50	7	3	7	9	16	11	3	2			
F	100	53	33	26	57	196	50K	7	3			
G	500	35	56	18	29	70	34	5	2			
H	1000	5	4	2	4	9	6	2	1			

**Figure 1.** Crosstalk observed without the ACT Plate Adapter and 10  $\mu$ L of 1 mM HCl in MeOH for methamphetamine and amphetamine

amphetamine												
	1	2	3	4	5	6	7	8	9	10	11	12
A	blank	6										
B	1	21										
C	5	8	23	100K	64					100K		
D	10		19	66	23							
E	50		14	21		22	38	25	17			
F	100					16	50K	70	12			
G	500					13	48	67	19			
H	1000											

methamphetamine												
	1	2	3	4	5	6	7	8	9	10	11	12
A	blank	2	3	4	5	3	5	2	3	3	3	2
B	1	26	8	8	13	6	4	3	4	4	4	2
C	5	9	19	100K	49	13	8	3	5	100K	2	1
D	10	7	18	41	17	9	11	7	7	6	2	3
E	50	8	13	12	10	16	26	22	12	6	3	1
F	100	3	3	7	7	10	50K	101	12	7	3	0
G	500	3	2	3	6	10	33	57	18	2	3	3
H	1000	3	3	3	4	7	12	15	8	4	1	

**Figure 2.** Crosstalk observed with the ACT Plate Adapter and 10  $\mu$ L of 1 mM HCl in MeOH for methamphetamine and amphetamine.

0.25% HCl												
amphetamine												
	1	2	3	4	5	6	7	8	9	10	11	12
A	blank	1	4	1	1	1	1	1	2	1	2	2
B	1	1	2	5	2	2	2	1	3	10	8	9
C	5	1	3	100K	3	2	1	3	8	53K	20	11
D	10	1	2	10	1	3	2	4	5		35	14
E	50	1	2	2	2	5	11	8	6	10	8	6
F	100	2	1	2	2	17	80K	23	10	6	7	4
G	500	3	1	2	3	9	31	21	6	5	8	4
H	1000	2	3	2	2	5	5	10	6	5	2	3

methamphetamine												
	1	2	3	4	5	6	7	8	9	10	11	12
A	blank	2	1	2	1	1	1	1	2	1	2	2
B	1	1	3	8	2	3	1	1	3	7	5	8
C	5	2	7	100K	5	3	2	1	5	53K	18	8
D	10	3	4	31	8	4	2	2	4	1	19	9
E	50	2	4	6	3	6	10	6	4	8	7	6
F	100	1	2	5	3	13	80K	16	5	5	5	2
G	500	1	1	2	2	6	28	15	3	3	6	2
H	1000	1	1	2	3	4	3	6	4	3	2	2

**Figure 3.** Crosstalk observed with the ACT Adapter and 10  $\mu$ L of 0.25% HCl in MeOH.

0.5% HCl												
amphetamine												
	1	2	3	4	5	6	7	8	9	10	11	12
A	blank	1	1	3	2	1	1	1	2	3	2	7
B	1	2	3	8	8	4	4	2	6	15	9	5
C	5	2	10	100K	25	7	3	3	9	53K	23	13
D	10	2	8	17	15	8	5	6	8	15	16	8
E	50	1	6	5	10	10	14	8	8	5	7	4
F	100	1	2	5	3	17	80K	18	11	9	4	5
G	500	1	1	3	8	13	29	18	16	10	1	2
H	1000	1	2	1	3	6	12	14	11	8	6	4

methamphetamine												
	1	2	3	4	5	6	7	8	9	10	11	12
A	blank	1	1	2	2	1	1	2	2	2	2	4
B	1	1	3	5	7	2	2	2	6	16	9	7
C	5	2	7	100K	14	4	2	3	9	53K	21	12
D	10	2	5	12	9	4	2	3	6	15	17	6
E	50	1	2	3	5	5	10	5	4	4	5	3
F	100	1	2	2	3	9	80K	9	4	4	2	4
G	500	1	1	1	2	5	13	8	7	4	5	1
H	1000	1	1	1	2	2	5	6	5	4	3	2

**Figure 4.** Crosstalk observed with the ACT Adapter and 10  $\mu$ L of 0.5% HCl in MeOH.

## Conclusions

Reducing evaporative crosstalk in urine assays with very high (>50,000 ng/mL) concentrations of volatile analytes can be challenging. The ACT Plate Adapter does reduce crosstalk for MDA, MDEA and MDMA, methamphetamine and amphetamine, but the correct concentration of HCl in MeOH is required to have enough HCl to “salt out” the methamphetamine and amphetamine present in very high concentration samples. The combination of 10  $\mu$ L of 0.5% HCl in MeOH and the use of the Biotage® ACT Plate Adapter reduced crosstalk to an acceptable concentration for most clinical and SAMHSA drug assays using urine specimen volumes of 150  $\mu$ L or less.

Elution volume also plays a role in reducing crosstalk. Reducing the urine volume (and hence sample volume) and using a 200  $\mu$ L ISOLUTE® SLE+ plate with half the elution volume (2 x 300  $\mu$ L) reduces the incidence of evaporative crosstalk even further (data not shown).

## References

1. Biotage, “SPE Dry 96 and SPE Dry 96 Dual User Manual” (2017) part number 415970-B.
2. Biotage, “ISOLUTE® SLE+ User Guide: Supported Liquid Extraction” (2016) part number UI304.V.3.
3. Biotage, “Current Methodologies for Drugs of Abuse Urine Testing: A White Paper from Biotage” (2019) part number PPS443.
4. <https://www.samhsa.gov/sites/default/files/workplace/2010-GuidelinesAnalytesCutoffs.pdf>. Accessed 04/14/2020.

# Your Complete Partner for Effective Chemistry

Biotage is a worldwide supplier of instruments and accessories designed to facilitate the work of laboratory and process chemists. With our deep knowledge of the industry, academic contacts and in-house R&D teams, we can deliver the best solutions to your challenges. We take great pride in our flexibility and ability to meet our customer's individual needs. With strong foundations in both analytical, organic and process chemistry, we can offer the widest range of solutions available on the market.

## EUROPE

Main Office: +46 18 565900  
Fax: +46 18 591922  
Order Tel: +46 18 565710  
Order Fax: +46 18 565705  
order@biotage.com  
Support Tel: +46 18 56 59 11  
Support Fax: +46 18 56 57 11  
eu-1-pointsupport@biotage.com

## NORTH & LATIN AMERICA

Main Office: +1 704 654 4900  
Toll Free: +1 800 446 4752  
Fax: +1 704 654 4917  
Order Tel: +1 800 446 4752  
Order Fax: +1 704 654 4917  
ordermailbox@biotage.com  
Support Tel: +1 800 446 4752  
us-1-pointsupport@biotage.com

## JAPAN

Tel: +81 3 5627 3123  
Fax: +81 3 5627 3121  
jp\_order@biotage.com  
jp-1-pointsupport@biotage.com

## CHINA

Tel: +86 21 68162810  
Fax: +86 21 68162829  
cn\_order@biotage.com  
cn-1-pointsupport@biotage.com

## KOREA

Tel: +82 31 706 8500  
Fax: +82 31 706 8510  
korea\_info@biotage.com  
kr-1-pointsupport@biotage.com

## INDIA

Tel: +91 11 45653772  
india@biotage.com

Distributors in other regions  
are listed on [www.biotage.com](http://www.biotage.com)

Part Number: PPS387.v2

© 2022 Biotage. All rights reserved. No material may be reproduced or published without the written permission of Biotage. Information in this document is subject to change without notice and does not represent any commitment from Biotage. E&OE. A list of all trademarks owned by Biotage AB is available at [www.biotage.com/legal](http://www.biotage.com/legal). Other product and company names mentioned herein may be trademarks or registered trademarks and/or service marks of their respective owners, and are used only for explanation and to the owners' benefit, without intent to infringe.

