

# EZ Twist Top® Split/Splitless Injection Ports

For Agilent 5890 GCs: cat.# 22725, 22726

## Before Starting:

1. Turn off the main power to the instrument and unplug the power cord from the receptacle. Allow adequate time for the instrument's heated zones to cool.
2. Turn off the main source of carrier gas to the instrument.

## Removing the Original Agilent Injection Port:

1. Consult the instrument manufacturer's handbook.

## Installing the EZ Twist Top® Injection Port:

1. Slide the insulation and the heater block onto the shell weldment. Screw the thermal nut onto the shell weldment. (Step not pictured.)
2. Place the shell weldment into the top of the oven. Run the gas lines as shown in Figure 1. Secure with the provided finger-tight nuts and O-rings.
3. Replace the split vent gas line onto the shell weldment. Tighten securely.
4. Place the dual Vespel® ring inlet seal into the reducing nut and screw onto the shell weldment.
5. Make sure the small Viton® O-rings are positioned correctly on the bottom of the weldment (Figure 2). When installing an inlet liner into the shell weldment, use a graphite or Viton® O-ring. Place the weldment on the top of the shell weldment. Align the pins on the weldment with the holes in the shell weldment. Thread the weldment onto the shell weldment. Tighten, using the weldment removal tool (cat.# 22728), (Figure 3).
6. Place a 11 mm septum into the split/splitless weldment. Tighten the septum nut.
7. Install the capillary nut and ferrule onto the column. Install the column.
8. Turn the carrier gas on and check for leaks using Restek's electronic leak detector (cat.# 22655). If an electronic leak detector is not available, perform a pressure decay test. If no leaks are present, replace the side panel and restore power.

## Changing the Inlet Liner on the EZ Twist Top® Injection Port:

1. Slip the weldment removal tool over the weldment. Push down on the tool to secure the weldment in the socket. Turn counter clockwise to loosen the weldment, then lift straight up. For speed and efficiency, the weldment stays secured in the weldment removal tool.
2. Replace the inlet liner and O-ring in the shell weldment. Examine the two small O-rings on the weldment and change accordingly.
3. Place the weldment onto the top of the shell weldment. Align the pins and slots. Tighten the weldment.
4. Leak check the injection port. If a leak is present, tighten the weldment ¼ turn at a time, leak checking after each ¼ turn.

## EZ Twist Top® Split/Splitless Injection Port for Agilent 5890 GCs

Description	qty.	cat.#
<b>Injection Port Assembly Kit</b>		
Includes: split/splitless weldment, shell weldment, 2 weldment O-rings, Siltek dual Vespel ring inlet seal, septum nut, reducing nut, stainless steel capillary nut for use with 1/16" ferrules, and weldment removal tool	kit	22725
<b>Injection Port Assembly Kit, Siltek Treated</b>		
Includes: Siltek split/splitless weldment, Siltek shell weldment, 2 weldment O-rings, Siltek dual Vespel ring inlet seal, septum nut, reducing nut, stainless steel capillary nut for use with 1/16" ferrules, and weldment removal tool	kit	22726
Weldment (2 weldment O-rings are installed on the weldment)	ea.	22724
Weldment, Siltek Treated (2 weldment O-rings are installed on the weldment)	ea.	22732
Shell Weldment	ea.	22727
Shell Weldment, Siltek Treated	ea.	22731
Weldment O-rings	10-pk.	22729
Septum Nut, Autosampler & PTV (for 23-gauge needles)	ea.	20631
Stainless Steel Capillary Column Nut (for use with standard 1/16" ferrules)	2-pk.	20883
Reducing Nut	ea.	22078
0.8 mm Dual Vespel Ring Inlet Seal, Siltek-Treated	2-pk.	21242
	10-pk.	21243
Weldment Removal Tool	ea.	22728

## Questions about this or any other Restek® product?

Contact us or your local Restek® representative ([www.restek.com/contact-us](http://www.restek.com/contact-us)).

Restek® patents and trademarks are the property of Restek Corporation. (See [www.restek.com/Patents-Trademarks](http://www.restek.com/Patents-Trademarks) for full list.) Other trademarks in Restek® literature or on its website are the property of their respective owners. Restek® registered trademarks are registered in the U.S. and may also be registered in other countries.

© 2015 Restek Corporation. All rights reserved. Printed in the U.S.A.

[www.restek.com](http://www.restek.com)

#203-02-029 Rev. date: 11/15

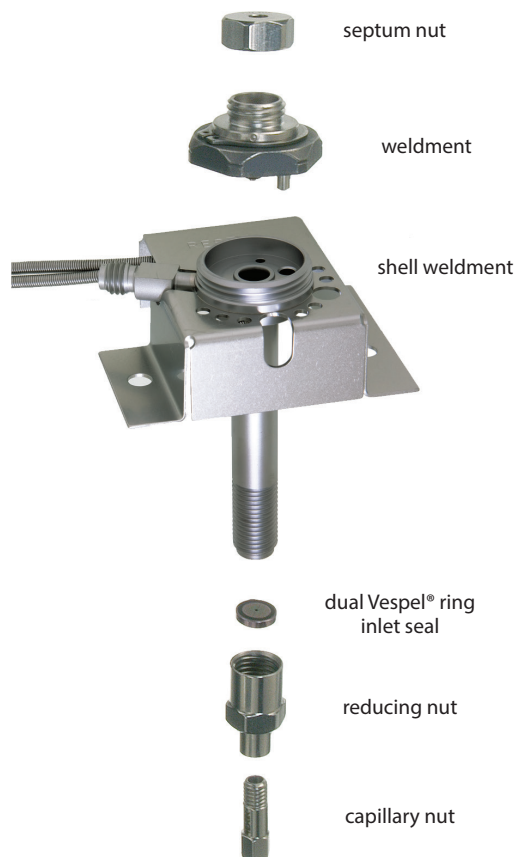

Figure 1

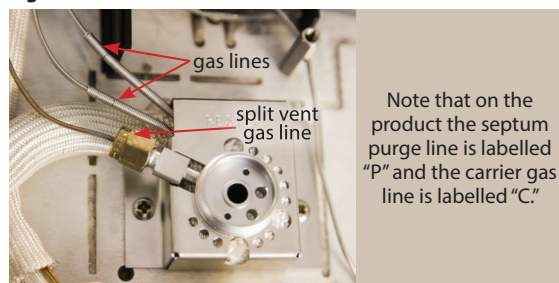

Figure 2

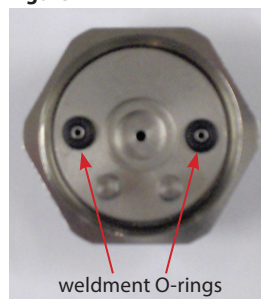

Figure 3

