

# Hot Injection Adapter Kit - Installation Guide

This guide provides the instruction for installing the Hot Injection Adapter kit (P/N 19050733) on the SSL/SSLBKF injector for the use with an external device for gas sampling. See [Figure 1](#).

**Figure 1.** Hot Injection Adapter



Hot Injection Adapter

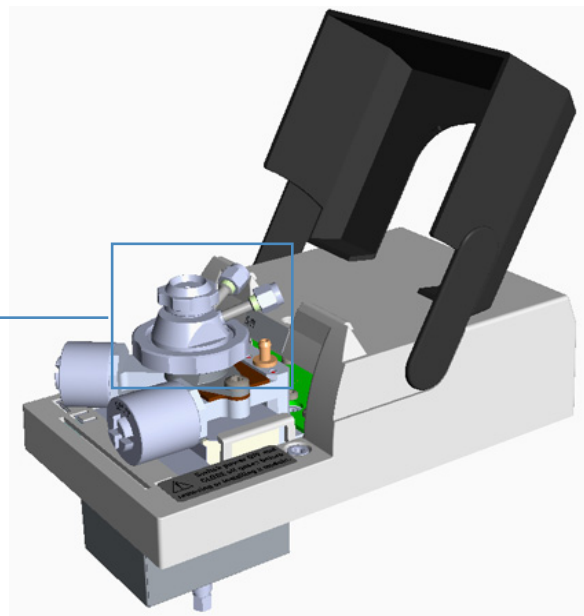

## Introduction

The Hot Injection Adapter consists of the following parts: head, short PTV liner, liner seal, and stem. See [Figure 2](#).

**Figure 2.** Hot Injector Adapter Assembly

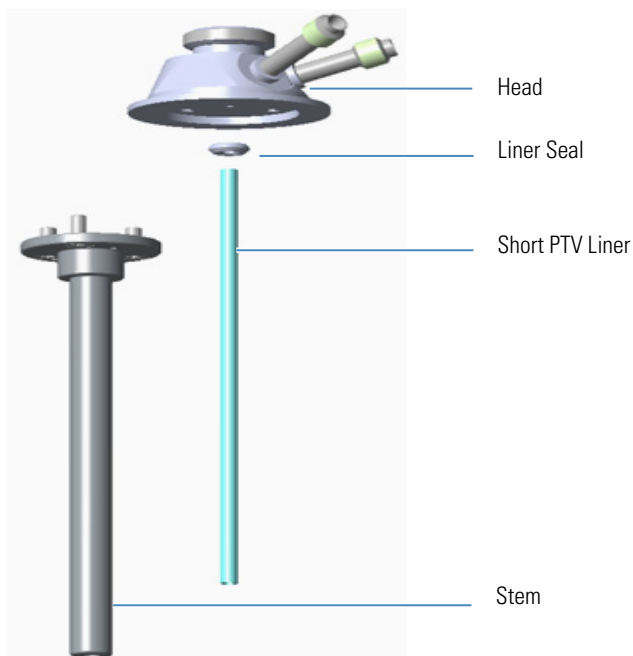

## Installing the Adapter

### ❖ To install the hot injection adapter on the injector:

1. Assemble the hot injection adapter if not already done. See Figure 3.

**Figure 3.** Adapter Assembly

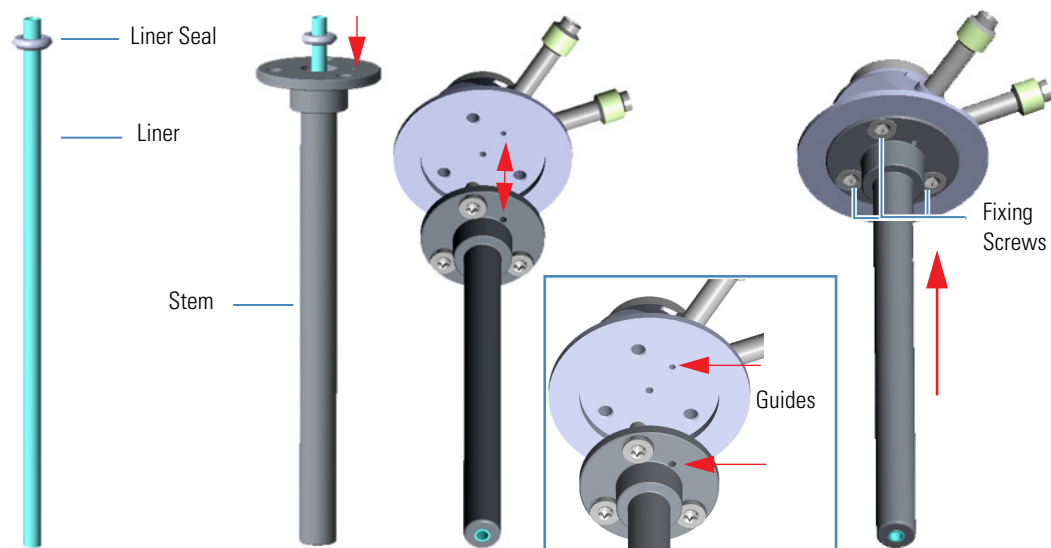

- a. Place the liner seal on the liner.
- b. Insert the liner into the stem.
- c. Couple the head and the stem paying attention to properly align the corresponding holes doing match the polarizing guides on the head and on the flange of the stem.
- d. Fix the stem to the head screwing the three fixing screws using a T8 Torxhead screwdriver.

**Note** The stem conducts heat from the body of the SSL/SSLBKF injector to the head of the adapter allowing a hot injection.

2. Put the GC in standby condition.
3. Cool the oven, injector, and detector to room temperature.

**Note** By pressing the **Maintenance** button, the GC cool down is automatically carried out.

4. Close the gas supplies.
5. Power off the GC.
  - a. Push down the power switch (breaker), located at the back of the instrument, to the position O.
  - b. Unplug the power cable from the AC Input connector into the back of the GC and from the wall outlet.
6. Remove the column end from the injector.
  - a. Open the front door of the GC.
  - b. Loosen the retaining nut from the injector fitting on the upper interior wall of the GC oven.
  - c. Remove the analytical column with its nut and ferrule from the bottom of the injector.
7. Put the autosampler away if present.
8. Remove the SSL/SSLBKF injector module from its seat.
  - a. Open the module flap cover.
  - b. Using a T20 Torxhead screwdriver, unscrew the three captive fixing screws.
  - c. Throw upward the module from its seat of the injector housing. Place the SSL/SSLBKF module on a clean surface.

**WARNING** Make sure the o-ring remains into its seat on the gas connection.  
**Do not install the module if the o-ring is missing.**

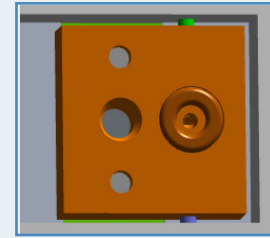
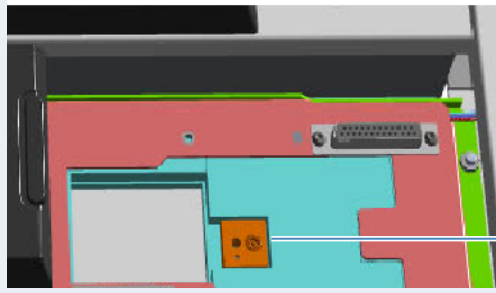

O-ring

9. Replace the module flap cover with the one provided. See [Figure 4](#).

**Figure 4.** Module Flap Cover for Hot Injection

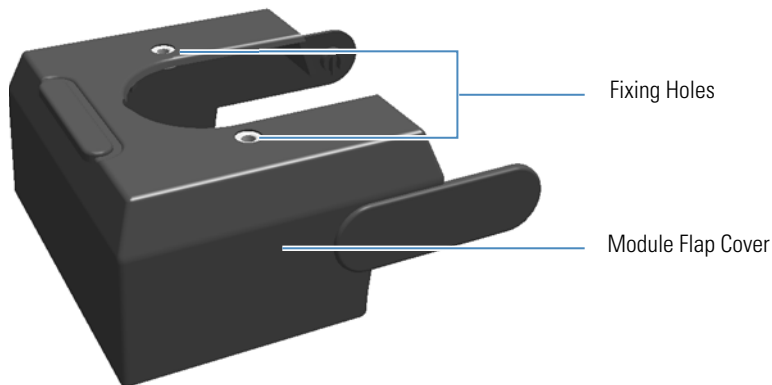

**Note** The fixing holes present on the top of the module flap cover can be used for making more stable a sampling device that requires to be seat directly on the injector.

10. Reinstall the injector module into the main frame.
  - a. Open the module flap cover.
  - b. Place the injector module in its seat. Be sure to insert the 25-pin male connector, on the bottom of the module, into the 25-pin female connector on the injector seat of the injector housing.
  - c. Use a T20 Torxhead screwdriver to tighten the three captive fixing screws without overtighten.



**CAUTION** To maintain the correct alignment the screws must be tightened in turn. Tighten each screw only a small amount before moving to the next screw. Repeat until all are secure.

11. Remove the top parts of the injector. See [Figure 5](#) on [page 4](#)

**Figure 5.** Injector Top Parts Removal

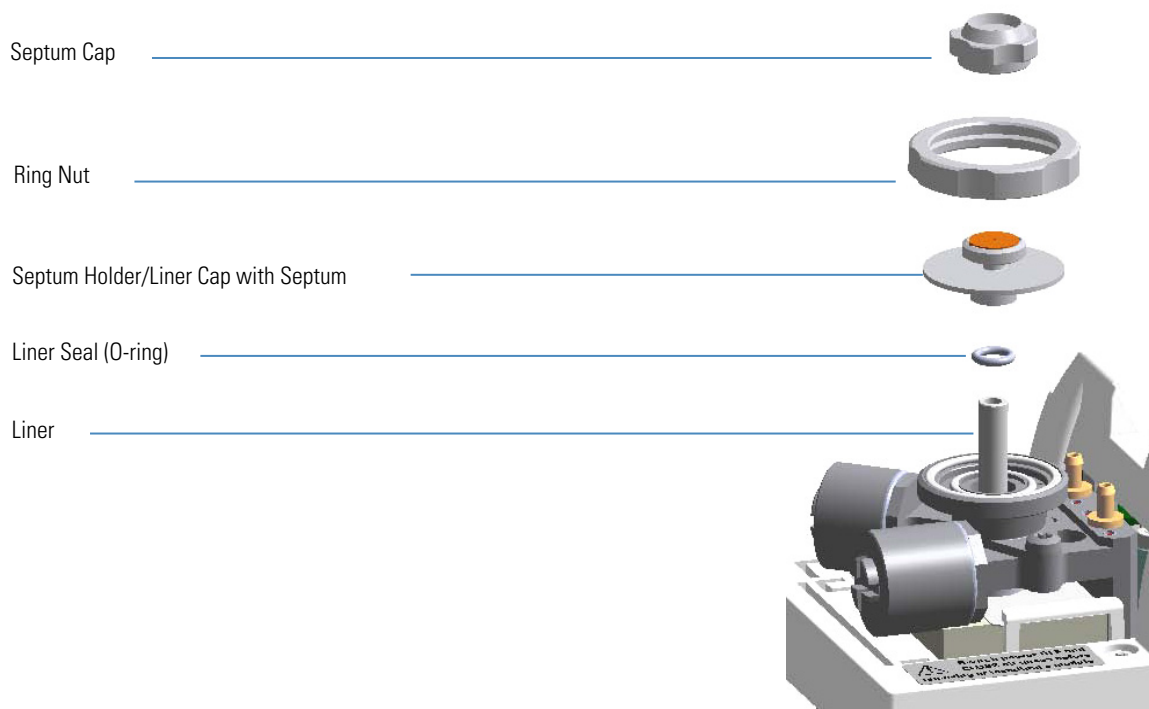

- a. Unscrew the septum cap of the injector.
  - b. Unscrew the ring nut.
  - c. Remove the septum holder/liner cap with septum from the injector body head.
12. Remove the liner and its seal.
- a. Use tweezers to remove the current liner with the liner seal (o-ring) from the injector.
13. Remove the injector body. See [Figure 6](#).

**Figure 6.** SSL Injector Body Removal

SSL/SSLBKF Injector Body Fixing Screws

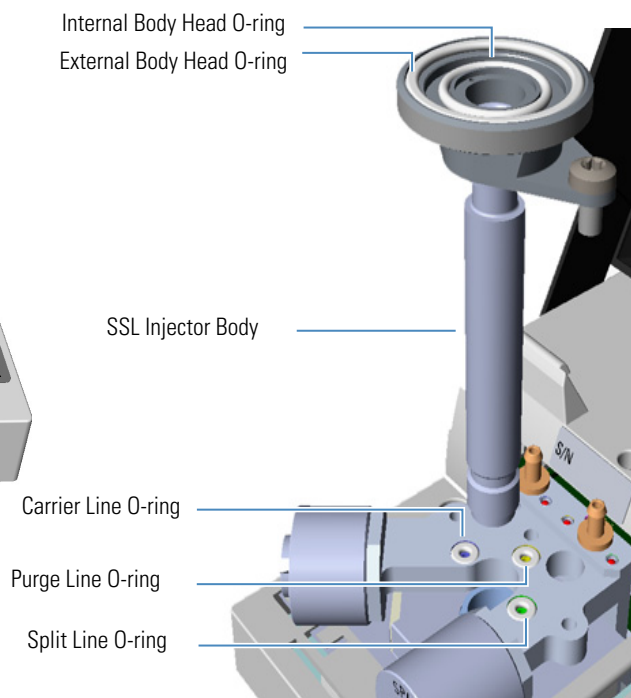
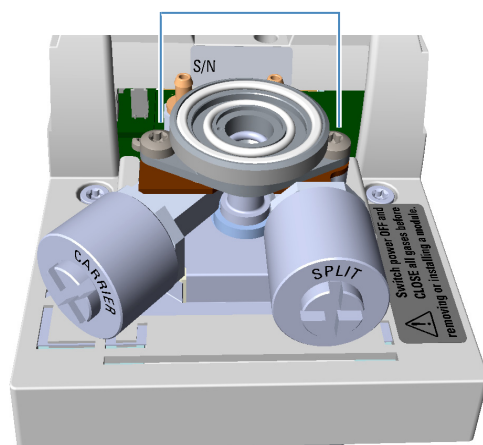

- a. Using a T20 Torxhead screwdriver, undo the two injector body fixing screws, and extract the injector body from its housing.

**Note** Do not remove the carrier, split, and purge lines o-rings.

14. Install the spacer plate. See [Figure 7](#).

**Figure 7.** Spacer Plate

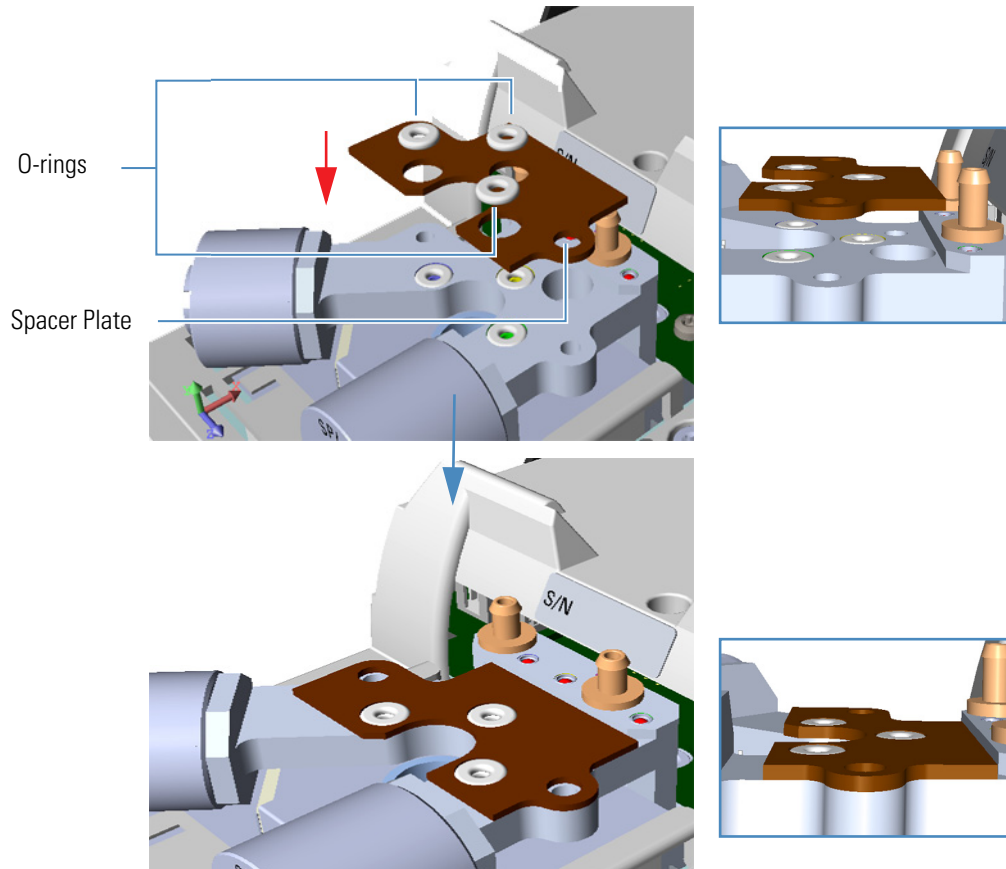

- a. Place the spacer plate and its three o-ring on the injector base.

**Note** The three o-ring of the spacer plate do not replace the carrier, purge, and split lines o-rings but are put on them, then six o-rings are present on the base.

15. Reinstall the injector body. See [Figure 8](#).

**Figure 8.** Injector Body Reinstallation

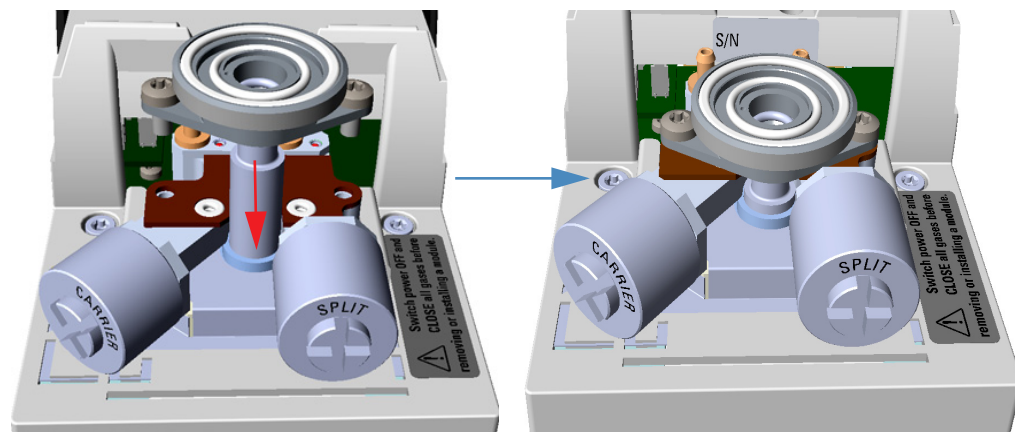

- a. Reinstall and fix the injector body into its housing by screwing the two fixing screws.
- b. If required, replace both the internal and external body head o-rings using tweezers.

16. Install the hot injection adapter on the top of the injector. See [Figure 9](#).

**Figure 9.** Hot Injection Adapter (1)

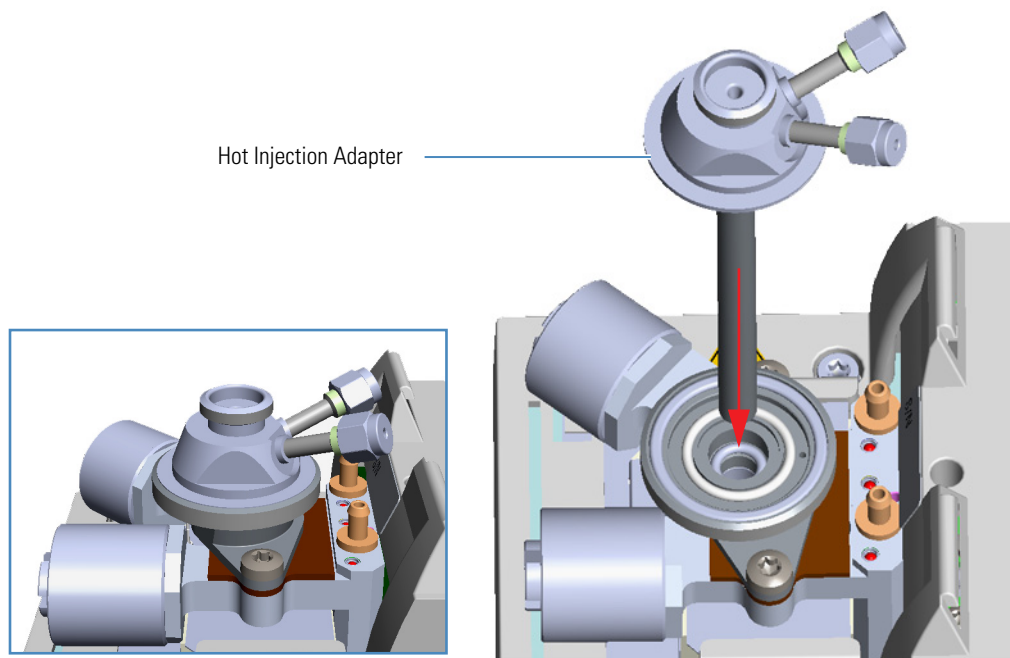

- a. Avoid touching the septum with your fingers. Insert a new septum into the septum holder cavity of the hot injection adapter using tweezers. See [Figure 10](#) on page 7.

**Figure 10.** Hot Injection Adapter (2)

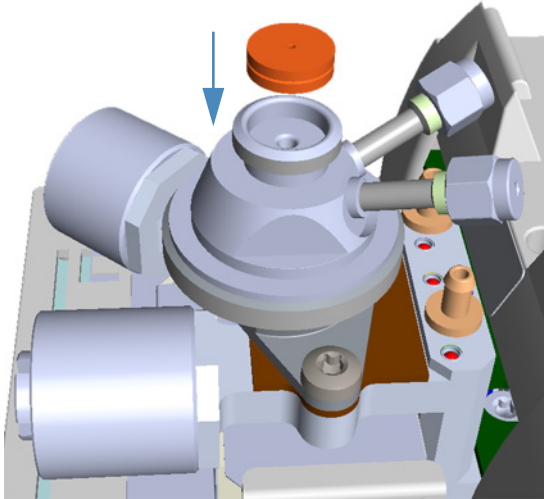

b. Guide the ring nut on the hot injection adapter with the septum, then fix it screwing the ring nut. See [Figure 11](#).

**Figure 11.** Hot Injection Adapter (3)

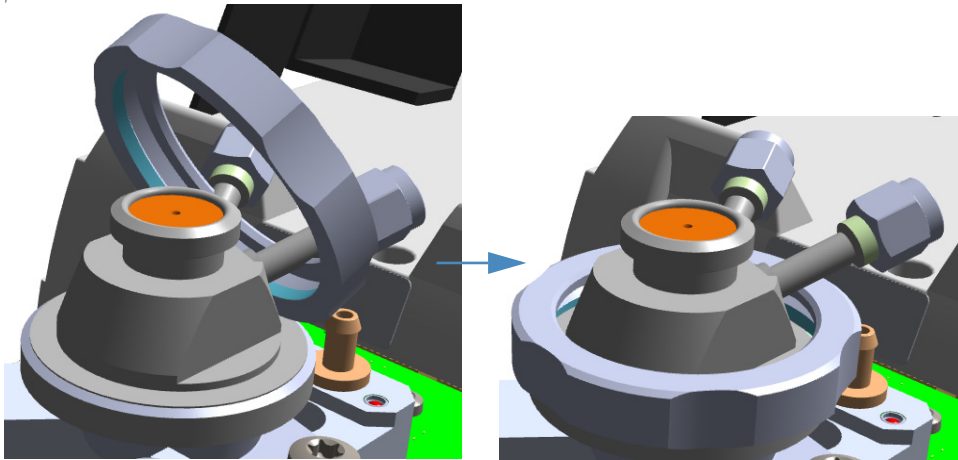

c. Screw and tighten the septum cap to finger-tight. See [Figure 12](#).

**Figure 12.** Hot Injection Adapter (4)

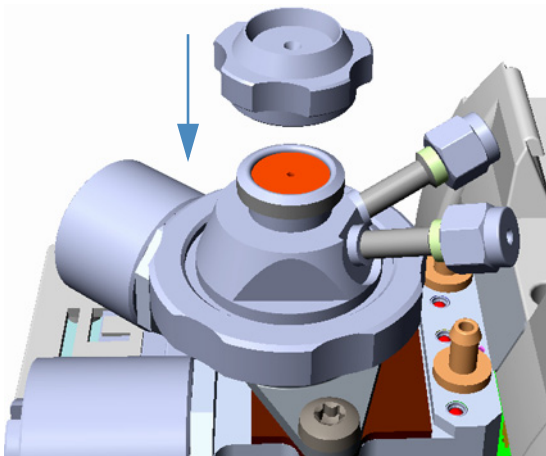

**CAUTION** Do not overtighten the septum cap because you might damage the septum and affect instrument performance.

17. Close the module flap cover.
18. Connect the hot injection adapter to the device for the sampling of gas. See the example in [Figure 13](#).

**Figure 13.** Hot Injection Adapter (5)

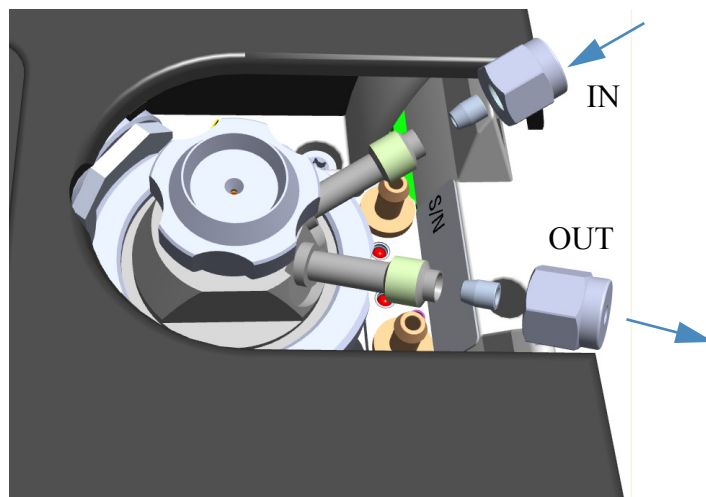

**CAUTION** If only a part of the adapter is connected to the device for the sampling of gas, close the other one with the blind nut provided.

19. Reconnect the column end to the injector and verify the connection point.
20. Open the gas supplies.
21. Power on the GC.
22. Plug the power cable to the AC Input connector into the back of the GC and to the wall outlet.
23. Flip out the power switch (breaker) to the position I.
24. Pressurize the module with the carrier gas.
25. Check for leaks.
  - a. Use a handheld electronic leak detector (Thermo Scientific GLD Pro leak detector or equivalent) to check the two fitting for leaks.
  - b. If you detect a leak, tighten the connection and retest it.
  - c. Repeat this process until all connections are leak free.
26. Close the front door of the GC.
27. If present, update the autosampler for the new injection position.