

# Hydrogen Detector User Manual



## Contents

Change History	3
How to use this Manual	3
Introduction	4
Warranties and Liabilities	5
Safety Notices	6
Symbols	6
Safety Notice to Users	6
Declaration of Conformity	7
Environmental Declaration	8
Technical Specification	9
Environment	9
Detector Inlets	9
Default Configuration	9
Electrical Requirements	9
General	9
Unpacking	10
Installation	11
Detector Environment	11
General Dimensions	12
Rear Connections	13
Fittings Kit	13
In Line Filter	13
Connecting to the GC	14
Tubing Lengths	15
Electrical Connection	16
Sensor Cartridge Installation	17
Start-up Sequence	19
IMPORTANT DOCUMENTS	20
Service Requirements	21
Service Schedule	21
Trouble Shooting	21

## Change History

Rev.	Comment	Name	Date
1	D.O.C. Altered	Liam Couttie	17/09/12
2	Connection Image Altered	Liam Couttie	31/10/12
3	GC Connection Info Added,	Liam Couttie	14/05/13
4	Fittings Kit Additions	Liam Couttie	03/09/13

## How to use this Manual

This manual is intended for end users and has been written so that it can either be read as a step by step guide to installation and usage or as a reference document where you can skip to the relevant information.

Users of a hard copy version can refer to the contents page to find the relevant information. Users of the soft copy version can use the hyperlinks from the contents page as well as the hyperlinks between sections.

Please review each of the following sections carefully.

Thank you for selecting Peak Scientific to meet your Gas Detection needs, and should you require any further assistance or support please do not hesitate to contact Peak Scientific or Peak Partner from which you purchased your Detector.

# H<sup>2</sup> Detector User Manual

## Introduction

The Peak Scientific Hydrogen Detector is an extractive gas sampling system that draws a sample locally from your GC Oven to a sensor cartridge that is located inside the detector's chassis.

Our Hydrogen Detector is wall mountable and displays gas concentration, alarm, fault and status information via its backlit LCD and LEDs. A simple to use 4-button keypad located under the display provides the facility to set-up, review, operate and make changes to the detector's configuration.



## Warranties and Liabilities

1. The Company warrants that it has title to the Goods.
2. Subject to the provisions of this clause the Company warrants that the Goods shall comply in all material respects with any specification referred to in the Order Confirmation (as the same may be amended) and shall, subject thereto, be free from defects in material and workmanship for the lesser of a period of twelve months from the date of delivery or thirteen months from the date of dispatch from the factory.
3. Save as provided in this clause and except where the Goods are sold to a person dealing as a consumer (within the meaning of the Unfair Contract Terms Act 1977) all warranties, conditions or other terms implied by statute or common law are hereby expressly excluded save to the extent they may not be lawfully excluded. When the Goods are sold to a consumer within the meaning of the Unfair Contract Terms Act 1977 their statutory rights are not affected by the provisions of this clause.
4. In the event of the Customer making a claim in respect of any defect in terms of clause 2 hereof the Customer must.
  1. Reasonably satisfy the Company that the Goods have been properly installed, commissioned, stored, serviced and used and without prejudice to the generality of the foregoing that any defect is not the direct or indirect result of lack of repair and/or servicing, incorrect repair and/or servicing, use of wrong materials and/or incorrect spare parts
  2. Allow the company to inspect the Goods and/or any installation and any relevant packaging as and when reasonably required by the Company.
5. Subject to the Company being notified of any defect as is referred to in sub-clause 2 hereof within a reasonable time of it becoming apparent and subject always to the terms of sub-clause 4 hereof, the Company shall, in its option, replace or repair the defective Goods or refund a proportionate part of the Price. The Company shall have no further liability to the Customer (save as mentioned in sub-clause 6 hereof).
6. The Company shall be liable to indemnify the Customer in respect of any claim for death or personal injury to any person in so far as such is attributable to the negligence or breach of duty of the Company or any failure by the Company to comply with the provisions of sub-clause 2 hereof.
7. Save as provided in sub-clause 2 hereof the Company shall not be liable in respect of any claim by the Customer for costs, damages, loss or expenses (whether direct, indirect, consequential or otherwise) or indemnity in any respect howsoever arising including, but not by way of limitation, liability arising in negligence (other than pursuant to clause 6 above) that may be suffered by the Customer or any third party.

## Safety Notices

### Symbols

This manual uses the following symbols to highlight specific areas important to the safe and proper use of the detector

	A <b>WARNING</b> notice denotes a hazard. It calls attention to an operating procedure, process or similar, which if not correctly performed or adhered to, could cause personal injury or in the worst case death. Do not proceed beyond a <b>WARNING</b> notice until the indicated conditions are fully understood or met.
	A <b>CAUTION</b> notice denotes a hazard. It calls attention to an operating procedure, process or similar, which if not correctly performed or adhered to, could cause damage to the Detector or the Application. Do not proceed beyond a <b>CAUTION</b> notice until the indicated conditions are fully understood or met.
	Caution, risk of electric shock. Ensure power to the Detector has been removed before proceeding.

### Safety Notice to Users



These instructions must be read thoroughly and understood before installation and operation of your Peak Hydrogen Detector. Use of the Detector in a manner not specified by Peak Scientific MAY impair the SAFETY provided by the equipment.



When handling, operating or carrying out any maintenance, personnel must employ safe engineering practices and observe all relevant local health and safety requirements and regulations. The attention of UK users is drawn to the Health and Safety at Work Act 1974, and the Institute of Electrical Engineers regulations.



If the equipment is used in a manner not specified by the manufacturer, the protection provided by the equipment may be impaired.

# H<sup>2</sup> Detector User Manual

## Declaration of Conformity

We **Peak Scientific Instruments Ltd.**

of **Fountain Crescent, Inchinnan. Renfrewshire PA4 9RE**  
declare that:

Equipment **Hydrogen Detector**

Model **Hydrogen Detector**

*To which this declaration relates, is in conformity with the applicable EC Directives, harmonized standards, and other normative requirements.*

- **Low Voltage Directive 2006/95/EC**  
EN 61010-1: 2010  
Safety Requirements for Electrical Equipment for Measurement, Control and Laboratory Use.  
Part 1: General requirements.
- **Electromagnetic Compatibility Directive 2004/108/EC**  
EN 50270 : 2006  
Electromagnetic compatibility - Electrical apparatus for the detection and measurement of combustible gases, toxic gases or oxygen.

*All evaluation, testing and certification issued by:*

**York EMC Services (2007) Ltd**  
Donibristle Industrial Park  
Dunfermline  
Fife  
KY11 9HZ

Signed By:



Name: Chris Pugh

Position: Engineering Director

Done at: Peak Scientific Instruments Ltd, Inchinnan, Scotland.

Date: 31<sup>st</sup> October 2012



# H<sup>2</sup> Detector User Manual

## Environmental Declaration

We **Peak Scientific Instruments Ltd.**

of **Fountain Crescent, Inchinnan. Renfrewshire PA4 9RE**  
declare that:

Equipment **Hydrogen Detector**

Model **Hydrogen Detector**

*Is fully compliant with the following Directives:*

**2002/96/EC WEEE (Waste of Electrical and Electronic Equipment)**

**2002/95/EC RoHS (Restriction of Hazardous Substances)**

Peak Scientific Instruments Ltd fully complies with its obligations towards the European WEEE (Waste of Electrical and Electronic Equipment) Directive 2002/96/EC. These obligations are being met within the B2B compliance group.

Peak Scientific Instruments Ltd has developed all reasonable 'due diligence' controls to ensure that our products comply with the principles and requirements of the European RoHS (Restriction of Hazardous Substances) Directive 2002/95/EC. Similar directives in the United States and China, for example, have also been captured within this program.

Where a specific certificate of compliance is required, this can be requested, on a product serial number basis, directly from Peak Scientific Instruments Ltd, by contacting us through our website on [www.peakscientific.com](http://www.peakscientific.com)

Signed By: 

Name: Chris Pugh

Position: Engineering Director

Done at: Peak Scientific Instruments Ltd, Inchinnan, Scotland.

Date: 29<sup>th</sup> August 2012





# H<sup>2</sup> Detector User Manual

## Technical Specification

### Environment

Minimum operating ambient temperature	0°C (40°F)
Maximum operating ambient temperature	40°C (104°F)
Maximum relative humidity	90% Non-Condensing
Minimum storage temperature*	0°C (40°F)
Maximum storage temperature*	40°C (104°F)

\*NOTE - When taken out of storage the Detector should be allowed to acclimatize at room temperature for a minimum of 3 hours before operation.

### Detector Inlets

Mass Flow Rate	500 cc/min(10in/H <sub>2</sub> O max pressure/vacuum)
Transport time	2-30 seconds maximum
Ambient Point	In line air filter required (supplied)

### Default Configuration

Current source with:	1.0mA Fault 2.0mA Inhibit 3.0mA Maintenance Fault 4.0 to 20.0mA Gas Reading (normal operation) 21mA Over range		
	Toxic Gas	Flammable Gas	Oxygen
Full Scale(FS)	Typically 4 x Threshold Limit Value (TLV)	100% Lower Explosive Limit (LEL)	25% Volume (v/v)
Lowest Alarm Level (LAL)	Typically ½ TLV	10% LEL	5% v/v
Lower Detectable Level (LDL)	Typically 0.4 TLV	9% LEL	0% v/v
	The LDL is the minimum level that is reliably distinguishable from zero.		
Alarm 1 (Relay 1)	½ TLV	10% LEL	23.5% v/v (rising)
	Normally de-energized, energizes on alarm. Contact Normally Open (NO), Closes on alarm.		
Alarm 2 (Relay 2)	TLV	20% LEL	19.5% v/v (Falling)
	Normally De-energized, de-energizes on alarm. Contact Normally Open (NO), closes on alarm.		
Fault (Relay 3)	Normally energized, de-energizes on fault. Contact normally open (NO). Instrument Fault only.		
Latching	Latching Alarm and fault relay DO NOT automatically reset when reading falls below alarm thresholds. Relays MUST be manually reset.		
Pass Code	No pass code set.		

### Electrical Requirements

The Detector has its power supplied by the Precision 500 generator
--

### General

Detector dimensions in cm W x D x H	6.3 x 16.2 x 20 (2.5" x 6.4" x 7.9")
Detector weight	1.8 kg (3.9 lb.)
Shipping crate dimensions in cm W x D x H	40 x 40 x 15 (15.7" x 15.7" x 5.9")
Shipping weight	3 kg (6.6 lb.)

# H<sup>2</sup> Detector User Manual

## Unpacking

Although Peak Scientific takes every precaution with safe transit and packaging, it is advisable to fully inspect the unit for any sign of transit damage.

Check 'SHOCKWATCH' label for signs of rough handling prior to un-packing -



Any damage should be reported immediately to the carrier and Peak Scientific or the Peak Partner from where the unit was purchased.

Please save the product packaging for storage or future shipment of the Detector.

Note: Included with the Detector is a "Fittings Kit" containing the communication cable for connecting the detector to the generator also all the required fittings. Be careful not to discard these with the packaging.

## Installation

### Detector Environment



The Detector is designed for use indoor safe non- explosive atmospheres only. It should be installed at a suitable height adjacent to the Gas Chromatograph it is connected to. Please see the [Tubing lengths](#) section for further details on maximum distances from the GC for maximum performance of the detector.



Performance of the Detector (like all sophisticated equipment) is affected by ambient conditions. Note should also be taken to the proximity of Air Conditioning outlets. These can sometimes give rise to “pockets” of air with high relative humidity. Operation of the unit within such a pocket could adversely affect its performance. Please refer to the drawing below for the general dimensions of the unit.

Maximum Ambient Conditions: 40°C (dry bulb) 90%RH (Max) Non-Condensing

### Location

The detector can be located on a flat surface or wall mounted for operation - this will ensure that you can locate it within the maximum distance required for the unit to successfully monitor for Hydrogen leaks.

The Peak Hydrogen Detector is supplied with a bracket to allow a simple way to mount the unit to a wall near the GC.

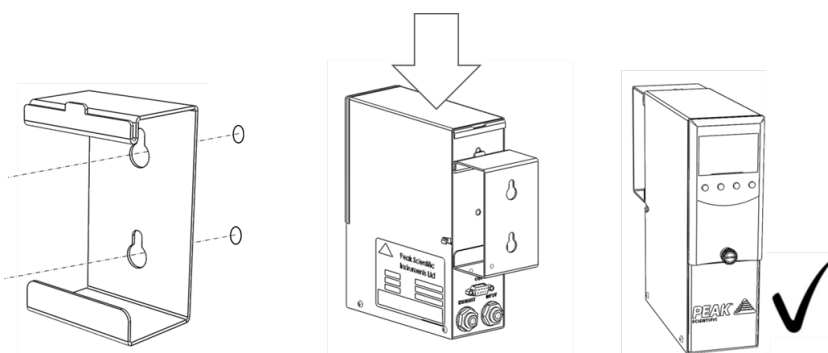

Use 2 x M4 Screws or equivalent (not supplied) for mounting the bracket to the wall. You will then be able to lower the detector unit onto the wall bracket. The wall mounting has been specially designed to allow greater serviceability by enabling the unit to be taken down off of the wall for service and maintenance work to be carried out, without having to remove the wall bracket.

# H<sup>2</sup> Detector User Manual

## General Dimensions

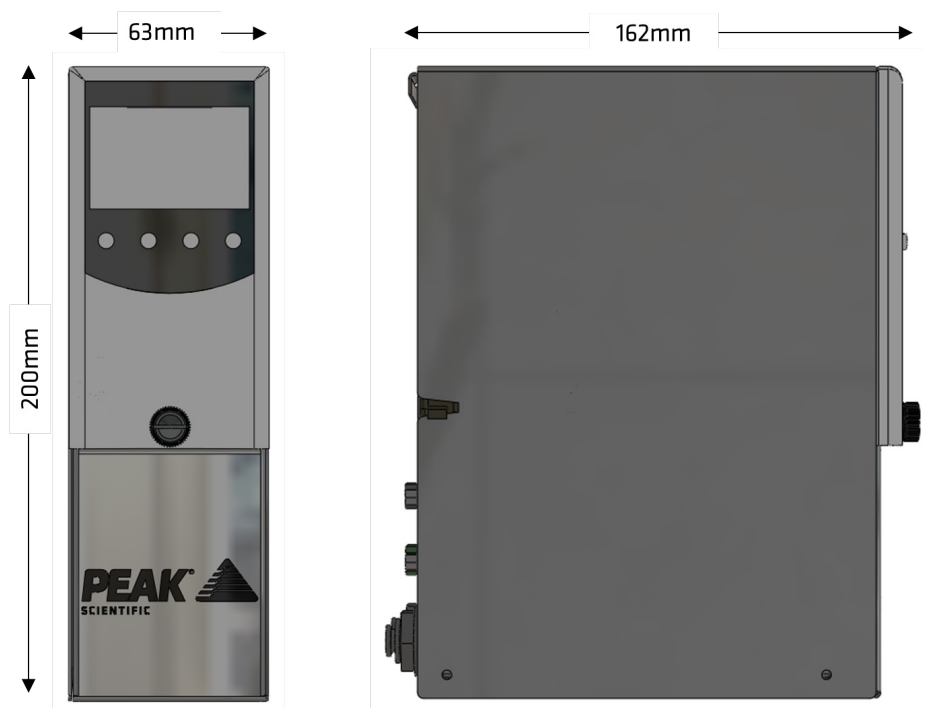

The Detector must always be placed on a level surface. Failure to do so will affect the performance of the Detector.

## Rear Connections

### Fittings Kit

Supplied in the Fittings Kit are all the fittings required to connect the Hydrogen Detector to the Generator. The contents of the Fittings Kit are as follows:

1. Communications Cable	× 1
2. In Line Filter	× 4
3. Cartridge	× 1
4. ¼" Push Fit Barbed Fitting	× 2
5. ¼" OD x ⅛" THK Exhaust Tubing	× 1.5m
6. ¼" OD x 3/16" THK Input Tubing	× 1.5m
7. ⅛" OD Stainless Steel Tubing	× 1m
8. Bulkhead Reducer Fitting	× 1
9. Tygon Filter Tubing	× 1m
10. Hex Key	× 1
11. Hose Clips	× 2
12. Wall Mounting Bracket	× 1
13. Installation Guide- Hydrogen Detector	× 1
14. User Manual CD- Hydrogen Detector	× 1

### In Line Filter

The In Line filter should be fitted, as close to the instrument as possible, on the end of the tubing which is connected to the Input port at the rear of the Detector, as shown below.

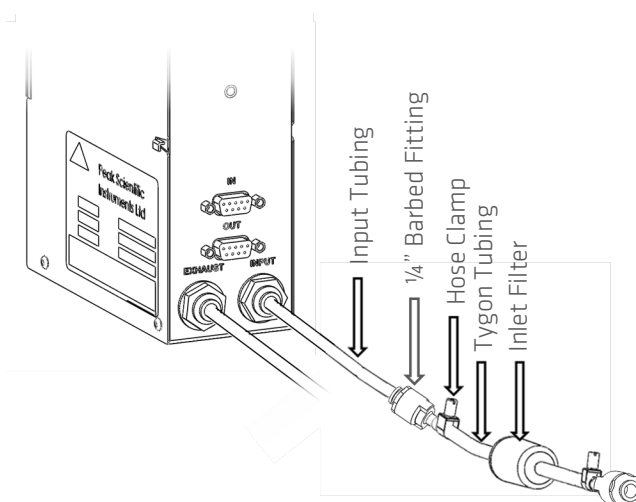

# H<sup>2</sup> Detector User Manual

## Connecting to the GC

1. First remove the plastic cover on the top of the GC.

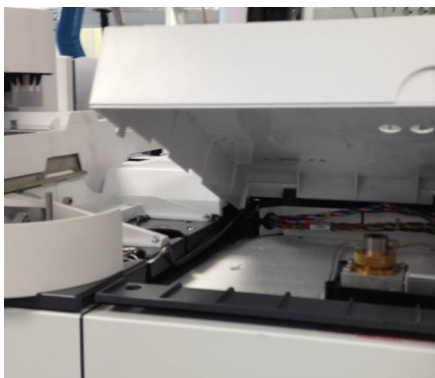

2. Locate the cut-out hole on the aluminium plate directly above the rear hole on the GC oven.

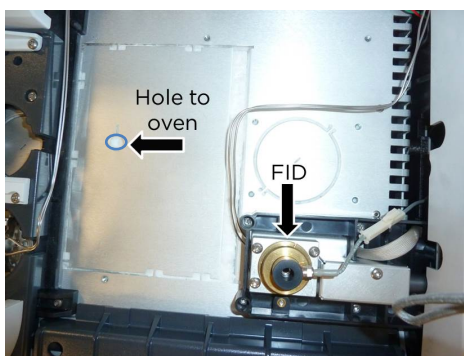

3. Make a hole through the insulation material, through to the oven. The stainless steel tubing from the detector can now be pushed through the hole, and secured in place using more insulation material.

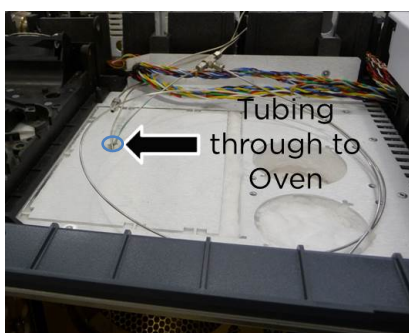

4. Once the stainless steel tubing has been pushed through and secured, the end of the tubing should be aimed at the inlet of the GC column.

# H<sup>2</sup> Detector User Manual

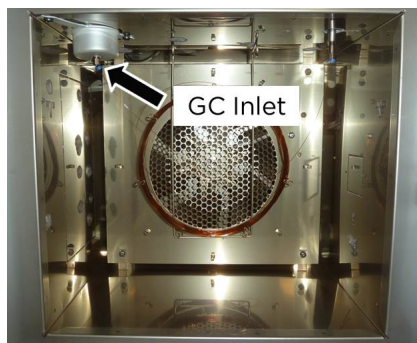

5. Position the end of the tubing as close to the inlet as possible, without limiting access for column changes and inlet maintenance.

6. The detector is now fully connected and will take samples continuously and both the detector and the H<sub>2</sub> generator will sound an alarm if dangerous levels of Hydrogen are detected. The generator will then shut down.

## Tubing Lengths



The length of the tubing which will be connected to the Input Port of the Detector is important and is determined by the Hydrogen cartridge used by the detector. Failure to follow these recommendations could lead to the Hydrogen Detector failing to operate efficiently.

Inlet Sample Specifications:				
	Maximum			
Tubing Length, m (ft.)	30 (100)	20 (66)	10 (33)	0
Transport Time (Sec)	28	19	10	1
Tubing OD, mm (in)	6.35 (0.25)			
Tubing ID, mm (in)	3.18 (0.125)			

# H<sup>2</sup> Detector User Manual

## Electrical Connection

Connect the Detector to the Peak Scientific Precision 500 Generator using the communication cable provided.

This unit is plugged, from the 'In' port at the rear on the detector, into the 'H<sub>2</sub> Detector' port at the rear of the generator, as shown below. This connection will provide the detector unit with power and allows communication between the Precision 500 and the detector unit.

The detector will take samples continuously and both the detector and the Precision 500 will alarm if dangerous levels of hydrogen are detected, the Precision 500 will then shut down.

Multiple detectors can be connected to one Precision 500. If this is desired, connect the first detectors 'Out' port to the second detectors 'In' port, as illustrated below. Please take into consideration when working with multiple Hydrogen Detector Units that a minimum required distance between units is 82mm (3.23in).

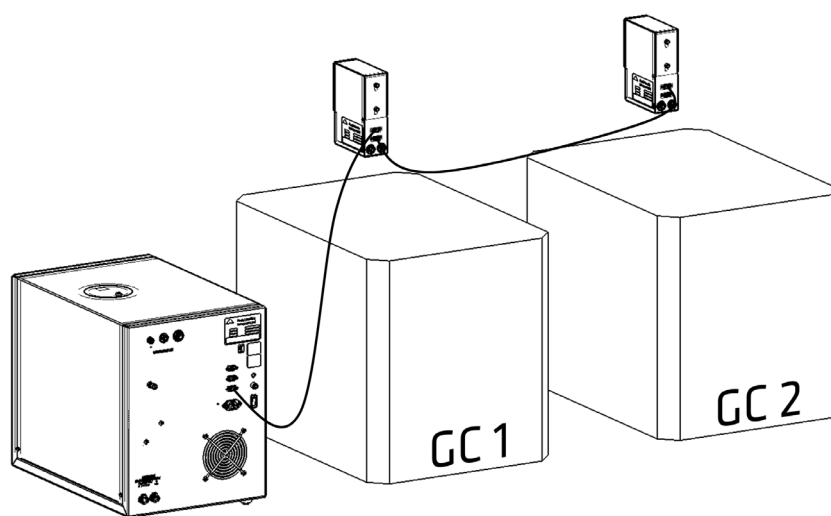
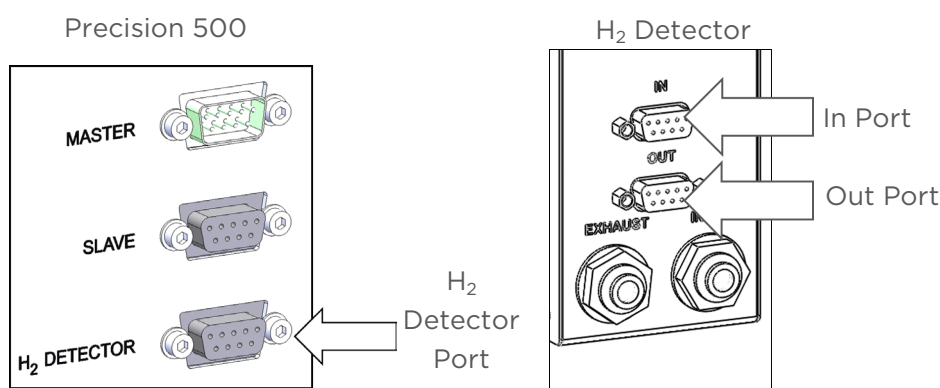



## Sensor Cartridge Installation

The pre-calibrated smart sensor cartridges can easily be fitted or replaced as they simply plug into the detector without the need for any tools. The sensor cartridge is firmly held in place by two locking tabs. Some cartridges are shipped with a protective cap to shield them from contaminants during shipping. This cap must be removed before inserting the cartridge into the Detector unit, failure to do so may damage the transmitter. Switch the power switch on the terminal module to the 'on' position and then re-fit the

Sensor warranty is void if the sensor cartridge is opened by unauthorised user.

\*The cartridge has an 'activate by' date that must be adhered to.

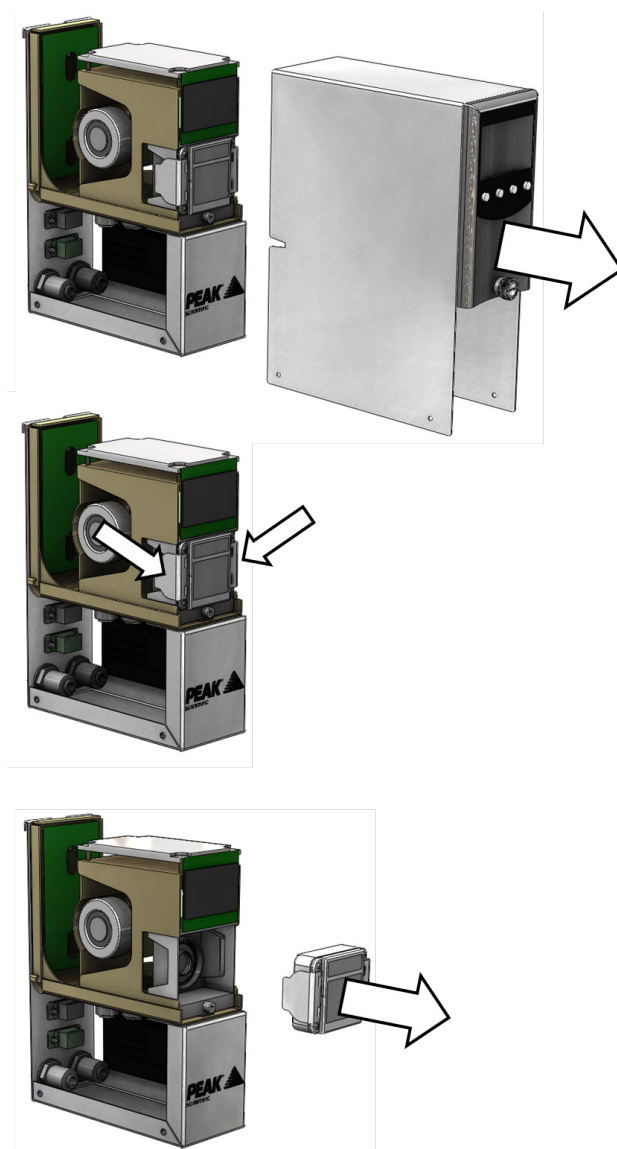

# H<sup>2</sup> Detector User Manual

In a first-time start up, an F49 or F88 fault code may be displayed; there is no actual fault and the fault message can be cleared by depressing the “X” button for a few seconds.

To properly activate the Detector with the cartridge for the first time:

1. When “ChAngE gAS” or “FIRSt CELL” scrolls on the display, hit the “✓” on the Detector front panel.
2. When the “reboot” completes then press and hold the “X” to clear any latched fault(s).
3. Confirm that the green LED is flashing.
4. Confirm that the yellow and red LEDs are off.
5. Confirm the display shows a concentration of zero (as appropriate).

The cartridge has now been accepted by the Detector as the correct type. If the above steps were not performed at initial start-up, the remove the cartridge and cycle power. Once the Detector has completed the “reboot” process, install the cartridge and repeat the steps above.

## Start-up Sequence

### CHECK:

1. Ensure power cable is correctly connected between the Hydrogen Generator and the Hydrogen Detector.
2. Hydrogen Generator is turned on.
3. After applying power to the Peak Scientific Hydrogen Detector the unit will run go through a start-up test routine illuminating in sequence all LEDs, icons and digits of the display. The unit will then display the messages "WAIT" and "LOAD" as it checks for the cartridge data, typically less than 180 seconds.
4. When complete, the detector will enter normal monitoring mode indicated by the icon on the display cycling through three states (2 rings, 3 rings, 4 rings). The measured gas concentration will be shown on the display. The green LED will flash once every second indicating power and the sample flow rate indicator will be displayed. If monitoring is interrupted due to a fault, a test or calibration process or a user requested inhibit, the display will flash, please refer to the Troubleshooting section for guidance. (See Figure 1)



Figure 1: Normal Operation

## IMPORTANT DOCUMENTS



## Warranty Entitlement

To register your generator for your warranty entitlement, send the completed form to Peak Scientific by:

- **Email** [warranty@peakscientific.com](mailto:warranty@peakscientific.com)
- **Online** [http://www.peakscientific.com/service-and-support/warranty\\_registration](http://www.peakscientific.com/service-and-support/warranty_registration)
- **Phone** +44 (0)141 530 4185
- **Fax** +44 (0)141 812 8200

PRODUCT WARRANTY REGISTRATION	
COMPANY:	CONTACT NAME:
ADDRESS:	
	EMAIL ADDRESS:
CITY/TOWN:	<b>DETECTOR SERIAL NUMBER:</b>
POSTCODE:	
COUNTRY:	MODEL TYPE:
TELEPHONE:	<b>INSTALLATION DATE (DD/MM/YYYY):</b>

### Important Please Note:

You have 1 month to register your Peak Scientific product from the date of shipment.

If you wish to defer installation of your detector you must notify Peak Scientific within 1 month of the shipment date. This can be done by emailing [warranty@peakscientific.com](mailto:warranty@peakscientific.com) Once registered the warranty will be honoured for a period of 12 months after the installation date.

For any generators that remain unregistered the warranty will begin from date of shipment.

Thank you on behalf of Peak Scientific.

## Service Requirements

### Service Schedule

Purchase Interval	Component	Part No.	Qty.
12 months	Detector Annual Service Kit	08-9003	1

Table 1: Annual Service Kit

## Trouble Shooting

Fault Code	Possible Solution
M10 Over Range – A large concentration has been detected. The Detector requires an independent confirmation that the gas hazard has gone.	<ul style="list-style-type: none"> <li>Supply known clean air to the Detector, and clear this fault.</li> <li>Contact Peak Service Provider.</li> </ul>
M12 Cartridge Expires Soon – Cartridge is old and will expire soon.	<ul style="list-style-type: none"> <li>Replace the cartridge with a new cartridge.</li> <li>Contact Peak Service Provider.</li> </ul>
M13 Flow Error – Detector is no longer able to regulate flow (high or low flow condition).	<ul style="list-style-type: none"> <li>Check filters and pump.</li> <li>Check pressure at inlet and outlet and assure they are within specification.</li> <li>Contact Peak Service Provider.</li> </ul>
M14 Interferent Present – An interferent is degrading the ability of the Detector to detect gas.	<ul style="list-style-type: none"> <li>Check application.</li> <li>Contact Peak Service Provider.</li> </ul>
M15 Temperature Near Limit – Temperature within 2 Celsius of limit.	<ul style="list-style-type: none"> <li>Check installation environment.</li> <li>Contact Peak Service Provider.</li> </ul>
M16 Baseline Fault – Sensor baseline has drifted.	<ul style="list-style-type: none"> <li>Check for background gas concentration, temperature or humidity fluctuations.</li> <li>Perform zero calibration.</li> <li>Replace cartridge.</li> <li>Contact Peak Service Provider.</li> </ul>
M17 Inhibit Timeout – Transmitter has been in inhibit mode too long	<ul style="list-style-type: none"> <li>Resume monitoring or increase timeout value.</li> <li>Contact Peak Service Provider.</li> </ul>
F40 Sensor Overdosed – Sensor has been exposed to high gas concentrations for long periods.	<ul style="list-style-type: none"> <li>Replace Cartridge.</li> <li>Contact Peak Service Provider.</li> </ul>
F43 Cartridge expired – Cartridge is too old.	<ul style="list-style-type: none"> <li>Replace Cartridge.</li> <li>Contact Peak Service Provider.</li> </ul>
F44 Cell Failure – Cartridge has failed reflex check.	<ul style="list-style-type: none"> <li>Replace Cartridge.</li> <li>Contact Peak Service Provider.</li> </ul>
F45 Stabilisation Timeout – Cartridge has failed to stabilise.	<ul style="list-style-type: none"> <li>If temperature or humidity shocks exist, precondition the cartridge.</li> <li>Check background gas concentration.</li> <li>Replace Cartridge.</li> </ul>

# H<sup>2</sup> Detector User Manual

	<ul style="list-style-type: none"><li>• Contact Peak Service Provider.</li></ul>
F46 Cartridge Analog Failure – Electronic Failure or gas concentration greater than full scale.	<ul style="list-style-type: none"><li>• Replace Cartridge.</li><li>• Contact Peak Service Provider.</li></ul>
F47 Cartridge Memory Invalid – Checksum Error.	<ul style="list-style-type: none"><li>• Replace Cartridge</li><li>• Contact Peak Service Provider.</li></ul>
F48 Cartridge Absent – No communications.	<ul style="list-style-type: none"><li>• Reseat Cartridge.</li><li>• Replace Cartridge.</li><li>• Contact Peak Service Provider.</li></ul>
F49 Cartridge Wrong Type – Cartridge type found to be incorrect after boot-up.	<ul style="list-style-type: none"><li>• Replace Cartridge or press ✓ to accept if correct.</li><li>• Contact Peak Service Provider.</li></ul>
F80 Temperature Limits Exceeded – Temperature is outside limits.	<ul style="list-style-type: none"><li>• Check installation environment.</li><li>• Contact Peak Service Provider.</li></ul>
F81 Flow Fail – Flow <70% of nominal for 15 seconds.	<ul style="list-style-type: none"><li>• Check Filters.</li><li>• Check for kinked tubing.</li><li>• Replace Pump.</li><li>• Contact Peak Service Provider.</li></ul>
F84 Misc. Transmitter Fault – Transmitter is defective.	<ul style="list-style-type: none"><li>• Service or replace Detector.</li><li>• Contact Peak Service Provider.</li></ul>

**Peak Scientific UK**

Fountain Crescent  
Inchinnan Business Park  
Inchinnan  
PA4 9RE  
Scotland, UK

**Tel:** +44 (0)141 812 8100

**Fax:** +44 (0)141 812 8200

**Peak Scientific Germany**

Herriotstrasse 1  
60528 Frankfurt

Germany

**Tel:** +49 (0)69 677 33 490

**Fax:** +49 (0)69 677 33 200

**Peak Scientific Taiwan**

4F.-6, No.736  
Zhongzheng Rd.  
Zhonghe Dist.  
New Taipei City

**Tel:** +886 2 8226 2383

**Fax:** +886 2 8226 9499

**Peak Scientific North America**

19 Sterling Road  
Suite #1  
Billerica, MA 01862

USA

**Tel:** +1 866 647 1649

**Fax:** +1 978 608 9503

**Peak Scientific China**

Room 606 Building 1  
Lane 2277 Zuchongzhi Road  
Pudong New Area  
Shanghai

201203, China

**Tel:** +86 21 5079 1190

**Fax:** +86 21 5079 1191

**Peak Scientific Brazil**

Peak Scientific Brasil  
Av. Quieroz Filho  
1700 - torre Sunny-Conj. 602  
São Paulo SP Brasil

**Tel:** +1 866 647 1649

**Peak Scientific India**

202, Amsri Shamira  
Old Lancer Line  
Opp. St. Mary's Degree College  
S.D. Road Secunderabad  
500 025, India

**Tel:** +91 40 2780 0663

**Fax:** +91 40 2780 0663

**Peak Scientific Mexico**

Solon 352  
Col. Los Morales Polanco  
11530 Mexico, D.F.

Mexico

**Tel:** +1 866 647 1649

**Fax:** +1 978 608 9503

**Peak Scientific Japan K.K.**

2-7-56, 2F Fuji Building 28  
Kita Aoyama, Minato-Ku  
Tokyo, Japan  
107-0061

**Tel:** +81 3-6864-0468

**Peak Scientific Africa**

PO Box 478  
Somerset Mall  
7137

South Africa

**Tel:** +27 (0)2185 16542

**Fax:** +27 (0)8654 64473

**Peak Scientific Australia**

PO Box 65  
Belmont  
Victoria 3216

Australia

**Tel:** +61 1300 965 352

**Peak Scientific Singapore**

3 Science Park Drive  
#03-14 The Franklin  
Science Park Drive 1  
Singapore, 118223

**Tel:** +65-6777 1966

**Fax:** +65-6777 1978