

# Vanquish Neo UHPLC system sets new performance standards for single-shot nanoLCMS bottom-up proteomics

## Authors

Runsheng Zheng<sup>1</sup>, Christopher Pynn<sup>1</sup>, Xuefei Sun<sup>2</sup>, Brandon H. Robson<sup>2</sup>, Alec Valenta<sup>1</sup>, Marijus Serys<sup>3</sup>, Lukas Taujenis<sup>3</sup>, Kean Woodmansey<sup>4</sup>, Stephan Meding<sup>1</sup>, Wim Decrop<sup>1</sup>, Martin Samonig<sup>1</sup>, and Alexander Boychenko<sup>1</sup>

<sup>1</sup>Thermo Fisher Scientific, Germering, Germany

<sup>2</sup>Thermo Fisher Scientific, Sunnyvale, CA, USA

<sup>3</sup>Thermo Fisher Scientific, Vilnius, Lithuania

<sup>4</sup>Thermo Fisher Scientific, Hemel Hempstead, UK

## Keywords

Vanquish Neo UHPLC system, Orbitrap Exploris 480, EASY-Spray PepMap Neo column, double nanoViper PepMap Neo column, bottom-up proteomics, deep proteome coverage, HeLa protein digest, PRTC standard, 1500 bar, 75  $\mu\text{m}$   $\times$  75 cm, pressure

## Goal

Demonstrate the superior performance of the Thermo Scientific™ Vanquish™ Neo next-generation low-flow UHPLC system for nanoLCMS bottom-up proteome profiling when coupled to a Thermo Scientific™ Orbitrap Exploris™ 480 mass spectrometer using the 75  $\mu\text{m}$  I.D.  $\times$  75 cm Thermo Scientific™ EASY-Spray™ PepMap Neo column. Demonstrate system versatility and potential for new levels of proteomic depth coverage through the coupling of two 75 cm long nano-columns.

## Introduction

Bottom-up proteomics research seeks to both identify and quantify the complete proteome within a cell, tissue, or organism. As the depth of proteome profiling increases, so does our insight into complex physiological processes and their effects on phenotype, potentially leading to advancements in fields including

biomarker discovery and precision medicine. The enormous variety and dynamic range of proteins found in biofluids such as human plasma or cells necessitates tools for high sensitivity, high specificity, and robust measurements.<sup>1-2</sup> In deep proteome profiling, nanoLC based methods using long columns and shallow gradients coupled to high-resolution mass spectrometers are used to characterize and identify as many peptides and proteins as possible. The past 20 years have seen significant innovation in LC-MS instrumentation for the separation and detection of peptides in digests, as well as in the power of the analysis tools required to analyze the increasingly complex data sets.

One key metric for quantifying performance in gradient chromatography is peak capacity, or the theoretical maximum number of fully resolvable peaks within a separation. At higher peak capacities more peptides are chromatographically resolved, leading to increased sensitivity for low level peptides and, ultimately, more identifications. For reversed-phase liquid chromatography, peak capacity is proportional to the square root of the column length.<sup>3</sup> Improving peak capacity requires either smaller particles or longer columns, both of which place increased pressure demands on nanoLC instruments. Longer (shallower) gradients have also been shown to improve peptide peak capacity in reversed-phase separations.<sup>4</sup> Classical proteomics workflows employ 75  $\mu\text{m}$  I.D. columns packed with 2  $\mu\text{m}$  particles operated at flow rates from 200 to 500 nL/min. Under such conditions, the use of columns longer than 50 cm severely limits sample throughput, in some cases to just a handful of samples/day.<sup>5</sup> Concomitant washing and equilibration steps coupled with system dead volume further limit sample throughput and MS utilization.

While downscaling column diameter can lead to improved method sensitivity, the main contributor to increased sensitivity at nano- and capillary-flow rates is the inverse relationship between flow rate and electrospray ionization (ESI) efficiency.<sup>6</sup> Additionally, lower flow rates afford enhanced sampling of analytes by the mass spectrometer and reduced ionization suppression by matrix components. As such, efforts to reduce analysis overhead time should focus on increasing the speed of sample loading and column equilibration while maintaining low-flow rates during the sample separation and MS data acquisition step. Similarly, efforts to keep the gradient delay volume to a minimum, by employing low volume nanoLC system designs together with optimized fluidic configurations are crucial considerations for maximizing analysis throughput and MS utilization in nanoLCMS analysis.

Another critical attribute in proteomics workflows is column-to-column reproducibility. Although high peak capacities enable deep proteome profiling, without reproducible separations across multiple columns it can be difficult to draw reliable conclusions.

Here we demonstrate the latest advances in nanoLCMS using the Vanquish Neo UHPLC system coupled with an Orbitrap Exploris 480 mass spectrometer for deep proteome profiling in HeLa cell protein digests. The Vanquish Neo extended pressure capabilities yield highly reproducible separations from 75  $\mu\text{m}$  I.D.  $\times$  50 cm and 75  $\mu\text{m}$  I.D.  $\times$  75 cm PepMap Neo columns for improved peak capacities and opens the door to the possibility of running even longer separation columns to achieve unsurpassed separation performance. Fast, sample loading and equilibration made possible via the 1500 bar pressure rating on both UHPLC system and consumables, deliver improved method throughput and increased MS utilization. Furthermore, advanced needle washing procedures minimize system carryover without wasting valuable MS duty cycle time. With a 4-hour gradient method, the identification of 80,000 peptides and over 7000 proteins in a single-shot nanoLCMS experiment with data-dependent acquisition (DDA) mode and more than 80% MS utilization for a direct sample injection workflow is achieved.

## Experimental materials and methods

### Sample preparation

Thermo Scientific™ Pierce™ HeLa Digest/PRTC Standard (A47996, 10  $\mu\text{g}/\text{vial}$ ) was reconstituted by adding 50  $\mu\text{L}$  of 0.1% formic acid (FA) in water. The vial was subsequently sonicated for 2 min, followed by aspirating and releasing 10-times with a pipette to fully reconstitute the sample. The sample was subsequently transferred to another vial of HeLa Digest/PRTC Standard (A47996), which was again sonicated for 2 mins and mixed in the same way to produce a final sample concentration of 400 ng/ $\mu\text{L}$  HeLa containing 200 fmol/ $\mu\text{L}$  PRTC.

### Consumables

- Fisher Scientific™ LC-MS grade Water with 0.1% Formic Acid (P/N LS118-500)
- Fisher Scientific™ LC-MS grade 80% Acetonitrile with 0.1% Formic Acid (P/N LS122500)
- Fisher Scientific™ LC-MS grade Formic Acid (FA) (P/N A117-50)
- Fisher Scientific™ LC-MS grade Isopropanol (P/N A461-212)
- Fluidics and columns used to setup Vanquish Neo system for direct injections and coupled with the Orbitrap Exploris 480 mass spectrometer are given in Table 1 and Figure 1.

Table 1. Fluidics and accessories for the direct injection workflow

Part number	Description	#
6PK1655	Vial and septa kit, 100/pack of <ul style="list-style-type: none"> <li>• Vial 0.2 mL amber TPX screw 9 mm short thread conical glass insert</li> <li>• Cap screw 9 mm black PP white silicone/red PTFE septa bonded 1.0 mm</li> </ul>	1
ES75500PN	Easy-Spray PepMap Neo 2 $\mu\text{m}$ 75 $\mu\text{m}$ $\times$ 500 mm 1500 bar	1
ES75750PN	Easy-Spray PepMap Neo 2 $\mu\text{m}$ 75 $\mu\text{m}$ $\times$ 750 mm 1500 bar	1
DNV75750PN	DNV PepMap Neo 2 $\mu\text{m}$ 75 $\mu\text{m}$ $\times$ 750 mm 1500 bar	1

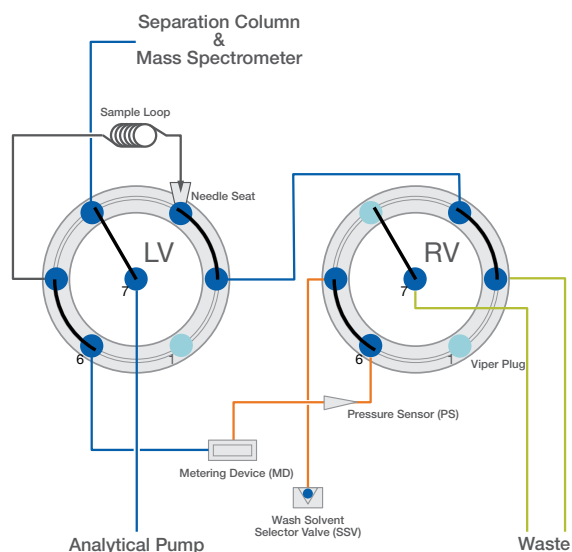

Figure 1. Vanquish Neo system coupled with the Orbitrap Exploris 480 mass spectrometer and scheme of direct injection workflow

### Vanquish Neo UHPLC system hardware

The Vanquish Neo system (VN-S10-A-01 and 6036.1180) comprises of a Vanquish binary Pump N, Split Sampler NT, Solvent Rack, and a Vanquish User Interface, System base with drawer, and Ship kit.

### LC solvents and system temperature settings

The solvents used to run nanoLCMS experiments and temperature parameters are given in Table 2.

Table 2. Solvents used for instrument operation

Module	Property	Setting
Binary Pump N	Mobile phase A	H <sub>2</sub> O with 0.1% FA
	Mobile phase B	80/20 (v/v) ACN/ H <sub>2</sub> O with 0.1% FA
Metering device	Weak wash liquid	H <sub>2</sub> O with 0.1% FA
	Strong wash liquid	80/20 (v/v) ACN/ H <sub>2</sub> O with 0.1% FA
Wash port	Weak wash liquid	H <sub>2</sub> O with 0.1% FA
	Strong wash liquid	80/20 (v/v) ACN/ H <sub>2</sub> O with 0.1% FA
Binary Pump N and metering device	Rear seal wash buffer	25/75 (v/v) H <sub>2</sub> O/ Isopropanol with 0.1% FA
Split Sampler NT	Temperature control	7 °C
Column Compartment N*	Temperature control	60 °C
Thermo Scientific™ EASY-Spray™ Source	Temperature control	50 °C

\* Only used for coupling double nanoViper PepMap Neo column and EASY-Spray PepMap Neo column experiments

FA = Formic acid, ACN = Acetonitrile

## Vanquish Neo configuration and parameters

The Vanquish Neo UHPLC system was configured using the Thermo Scientific™ Chromeleon™ Chromatography Data System (CDS) “Chromeleon Instrument Configuration Manager” panel of the Thermo Scientific™ Standard Instrument Integration (SII) for Xcalibur™ software with the IP address retrieved from the Vanquish User Interface in the “Settings: Connectivity” tab, as shown in Figure 2. The separation column type and column specifications were set on the VSC controller according to the column in use.

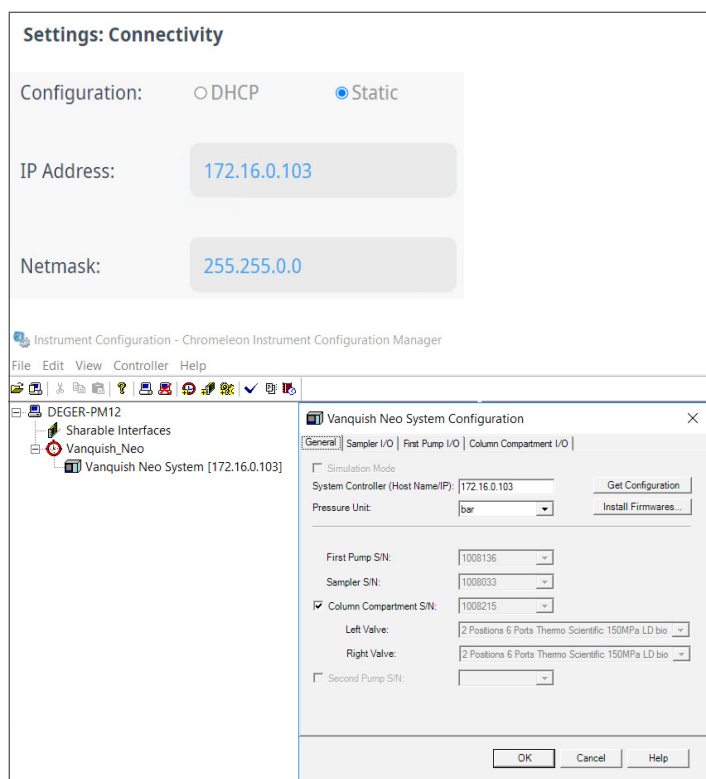

Figure 2. “Settings: Connectivity” tab on the Vanquish User Interface which is used to retrieve the IP address for automatic configuration of the Vanquish Neo UHPLC system in SII for Xcalibur

Parameters for sample aspiration, loading and column equilibration are shown in Table 3, with an example LC gradient in Table 4. All the LC gradients were programmed in SII for Xcalibur software for each column and method lengths, which are available for download from the Thermo Scientific™ [AppsLab Library](#).

Table 3. LC method parameters

Category	Parameter	Value
Sample loading	Fast loading	Enabled
	Mode	PressureControl
	Pressure	1500 bar
	Loading volume*	Automatic
Sample pick-up*	Outer needle wash mode	After draw
	Outer needle wash time (strong)	3.0 s
	Outer needle wash speed (strong)	80.0 µL/s
	Outer needle wash time (weak)	5.0 s
	Outer needle wash speed (weak)	80.0 µL/s
	Draw speed	0.2 µL/s
	Draw delay	2.0 s
	Dispense speed	5.0 µL/s
	Vial bottom detection	Enabled
Column equilibration	Fast equilibration	Enabled
	Mode	PressureControl
	Pressure	1500 bar
	Equilibration factor	2
Temperature	EASY-Spray column temperature	50 °C
	Autosampler temperature*	7 °C

\*System default values

Table 4. The 240-min gradient method

Time (min)	Duration (min)	Flow rate (µL/min)	%B
<b>Gradient separation phase</b>			
0	0	0.25	1
0.1	0.1	0.25	5
210.1	210	0.25	28
240.1	30	0.25	40
<b>Column wash phase</b>			
250.1	10	0.25	99
260	9.9	0.25	99

## MS acquisition parameters

MS data were recorded with an Orbitrap Exploris 480 mass spectrometer in DDA mode. An example of the MS data acquisition parameters is shown in Figure 3. All MS acquisition settings are available for download in the [AppsLab library](#) for all the methods reported here.

## Data acquisition and processing

Data were acquired using the SII for Xcalibur software package version 1.5.1 in data-dependent acquisition (DDA) mode, followed by .raw file processing with Thermo Scientific™ Proteome Discoverer™ 2.5 software using a 2-step Sequest™ HT search algorithm and INFERY rescoring node. The false discovery rate (FDR) was set below 1% at the peptide and the protein level. The data processing templates are also available for download in the [AppsLab library](#).

Method Summary	Experiment#1 [MS]	Filter Type: <b>Intensity Threshold</b> Intensity Threshold: <b>1.0e4</b>	Multiplex Ions: <b>False</b> Isolation Window (m/z): <b>2</b> Isolation Offset: <b>Off</b> Collision Energy Mode: <b>Fixed</b> Collision Energy Type: <b>Normalized</b> HCD Collision Energy (%): <b>26</b> Orbitrap Resolution: <b>15000</b> TurboTMT: <b>Off</b> Scan Range Mode: <b>Define First Mass</b> First Mass (m/z): <b>120</b> AGC Target: <b>Custom</b> Normalized AGC Target (%): <b>50</b> Maximum Injection Time Mode: <b>Auto</b> Microscans: <b>1</b> Data Type: <b>Centroid</b> Scan Description:
<b>Method Settings</b> Application Mode: <b>Peptide</b> Method Duration (min): <b>260</b>	Start Time (min): <b>0</b> End Time (min): <b>260</b> <b>Master Scan:</b> <b>Full Scan</b> Orbitrap Resolution: <b>60000</b> Scan Range (m/z): <b>375-1200</b> RF Lens (%): <b>45</b> AGC Target: <b>Custom</b> Normalized AGC Target (%): <b>300</b> Maximum Injection Time Mode: <b>Auto</b> Microscans: <b>1</b> Data Type: <b>Profile</b> Polarity: <b>Positive</b> Source Fragmentation: <b>Disabled</b> Scan Description:	<b>Charge State</b> Include charge state(s): <b>2-5</b> Include undetermined charge states: <b>False</b> <b>Dynamic Exclusion</b> Dynamic Exclusion Mode: <b>Custom</b> Exclude after n times: <b>1</b> Exclusion duration (s): <b>65</b> Mass Tolerance: <b>ppm</b> Low: <b>10</b> High: <b>10</b> Exclude isotopes: <b>True</b> Perform dependent scan on single charge state per precursor only: <b>True</b>	
<b>Global Parameters</b> <b>Ion Source</b> Ion Source Type: <b>NSI</b> Spray Voltage: <b>Static</b> Positive Ion (V): <b>1900</b> Negative Ion (V): <b>600</b> Gas Mode: <b>Static</b> Sweep Gas (Arb): <b>0</b> Ion Transfer Tube Temp (°C): <b>275</b> Use Ion Source Settings from Tune: <b>False</b> FAIMS Mode: <b>Not Installed</b>	<b>Filters:</b> <b>MIPS</b> Monoisotopic peak determination: <b>Peptide</b> Relax restrictions when too few precursors are found: <b>True</b> <b>Intensity</b>	<b>Data Dependent</b> Data Dependent Mode: <b>Number of Scans</b> Number of Dependent Scans: <b>25</b> <b>Scan Event Type 1:</b> <b>Scan:</b> <b>ddMS<sup>2</sup></b>	
<b>MS Global Settings</b> Infusion Mode: <b>Liquid Chromatography</b> Expected LC Peak Width (s): <b>25</b> Advanced Peak Determination: <b>True</b> Default Charge State: <b>2</b> Internal Mass Calibration: <b>Off</b>			

Figure 3. Example of Orbitrap Exploris 480 mass spectrometer parameters for the 240-min nanoLCMS gradient method

## Results and discussion

### The Vanquish Neo system supports longer separation columns for higher chromatographic performance

Commercially available 75  $\mu\text{m}$  I.D.  $\times$  50 cm columns are commonly associated with discovery proteomics applications on nanoLCMS platforms because they deliver high peak capacity in single-shot proteome profiling for both direct injection as well as trap-and-elute workflows.<sup>7</sup> The 75  $\mu\text{m}$  I.D.  $\times$  75 cm columns, on the other hand, have hitherto received less acclaim despite their capacity for deeper proteome profiling.<sup>8</sup> Wide-spread adoption of these columns has, in part, been hampered by the maximum pressure ratings of the available nanoLC systems, which have reduced the speed of column loading and equilibration even when the systems are operated at their maximum available pressures. This in turn limits the sample throughput, especially

in the direct injection workflow. The Vanquish Neo UHPLC system and separation columns, capable of robust operation at 1500 bar, can significantly accelerate the sample loading and column equilibration steps for both 50 cm and 75 cm long nano-columns (Figure 4). The increase in column length results in higher efficiency, lower full width at half maximum (FWHM), and ultimately to higher peak capacity. The 75  $\mu\text{m}$  I.D.  $\times$  75 cm column outperforms the 75  $\mu\text{m}$  I.D.  $\times$  50 cm in a 90-min gradient by reducing the FWHM by 2 seconds for 50% of the peptide peaks (Figure 5). In best-case scenarios, peak width was reduced by up to 4 seconds (Figure 5). As such, the employment of the long column on the Vanquish Neo UHPLC system affords distinct performance advantages for routine bottom-up proteomics research without compromising MS utilization time.

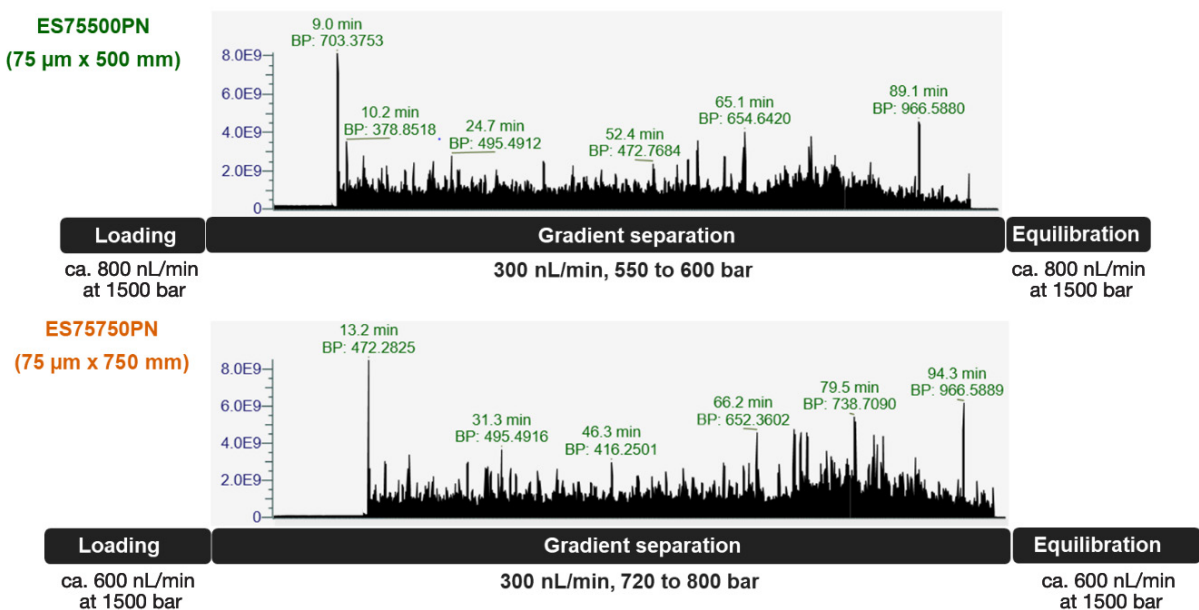

Figure 4. The Vanquish Neo UHPLC system enables fast sample loading and equilibration on 75  $\mu\text{m}$  I.D.  $\times$  50 cm and 75  $\mu\text{m}$  I.D.  $\times$  75 cm columns.

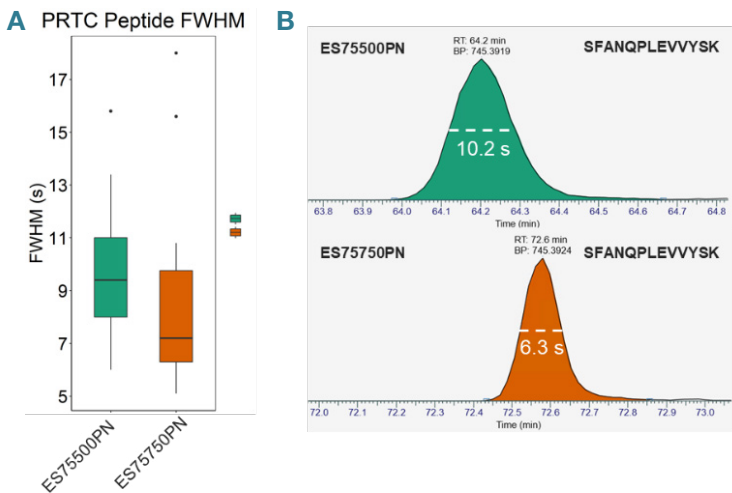

Figure 5. Comparison of FWHM for 75 cm vs. 50 cm columns in a 90-min gradient with 100 fmol PRTC spiked in HeLa protein digest reveal reductions of up to 2 seconds for 50% of peptides (A) and up to 4 seconds for certain peptides such as the PRTC peptide SFANQPLEVVYSK (B).

## The Vanquish Neo system provides reproducible nanoLC gradients to achieve maximum performance

Single shot nanoLCMS analyses require the highest possible separation efficiency to maximize the number of identified peptides and proteins. The increase of the gradient length by using long columns provides higher peak capacity, the theoretical number of fully resolved peaks, as it is proportional to gradient time divided by peak width. Despite an almost linear increase of FWHM with gradient length (Figure 6), the number of peptide and protein identifications tend to increase due to the extra time available for precursor ion isolation and fragmentation. Furthermore, the sensitivity losses incurred through the corresponding peak broadening with increased gradient length can be compensated by loading larger sample amounts in order to increase peak height (Figure 6). The detrimental effects of column overloading on FWHM, however, means that there are

limits to the sensitivity improvements that can be practically achieved (Figure 6). Interestingly no significant improvement of peptide and protein IDs was observed with increased loading amount (Figure 7).

By employing a 240-min gradient and loading 1  $\mu\text{g}$  HeLa protein digest, more than 7,100 proteins (1% FDR) with ca. 80K peptides were successfully quantified after separation on a 75 cm nano column. These data illustrate the power of high-resolution chromatography coupled with HRAM MS in boosting proteome depth and coverage. More than 80% of quantified peptides and 90% of proteins showed less than 25% abundance RSD over different gradients and sample amounts (Figure 8). The observed relative decrease in quantification precision with increased gradient length might be explained by a more challenging estimation of peak boundaries for wider chromatographic peaks (Figure 8).

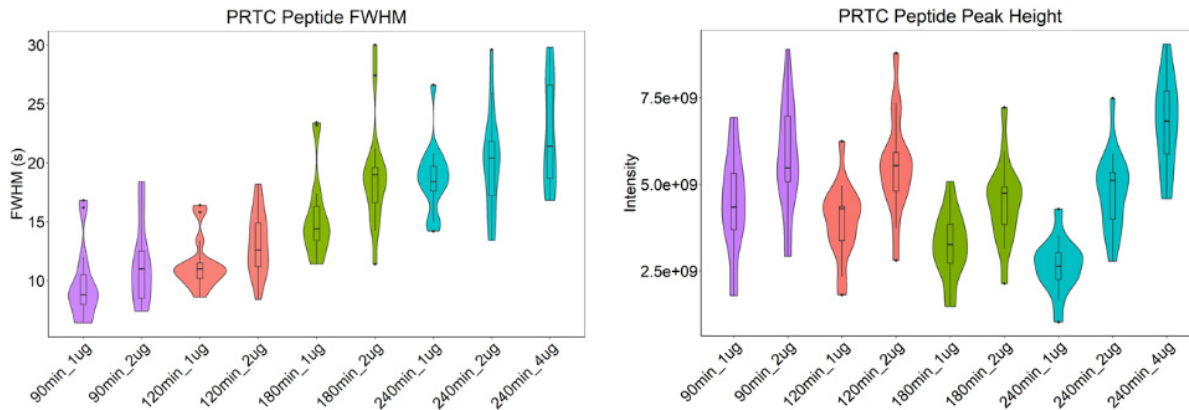

Figure 6. The dependency of FWHM and peak height on the gradient length using the constant flow rate (250 nL/min) and different loading amounts.

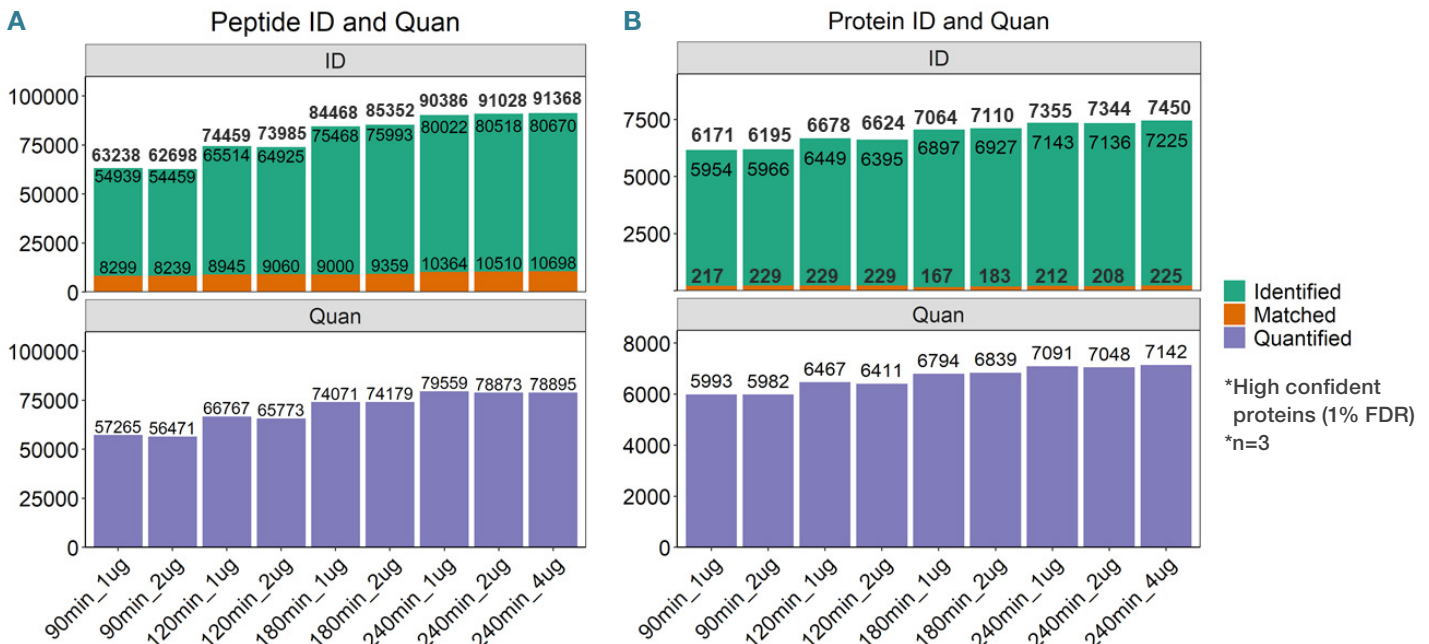

Figure 7. The number of peptides (A) and proteins (B) that were confidently identified and quantified using gradient length from 90 to 240 min and loading amount from 1 to 4  $\mu\text{g}$ .

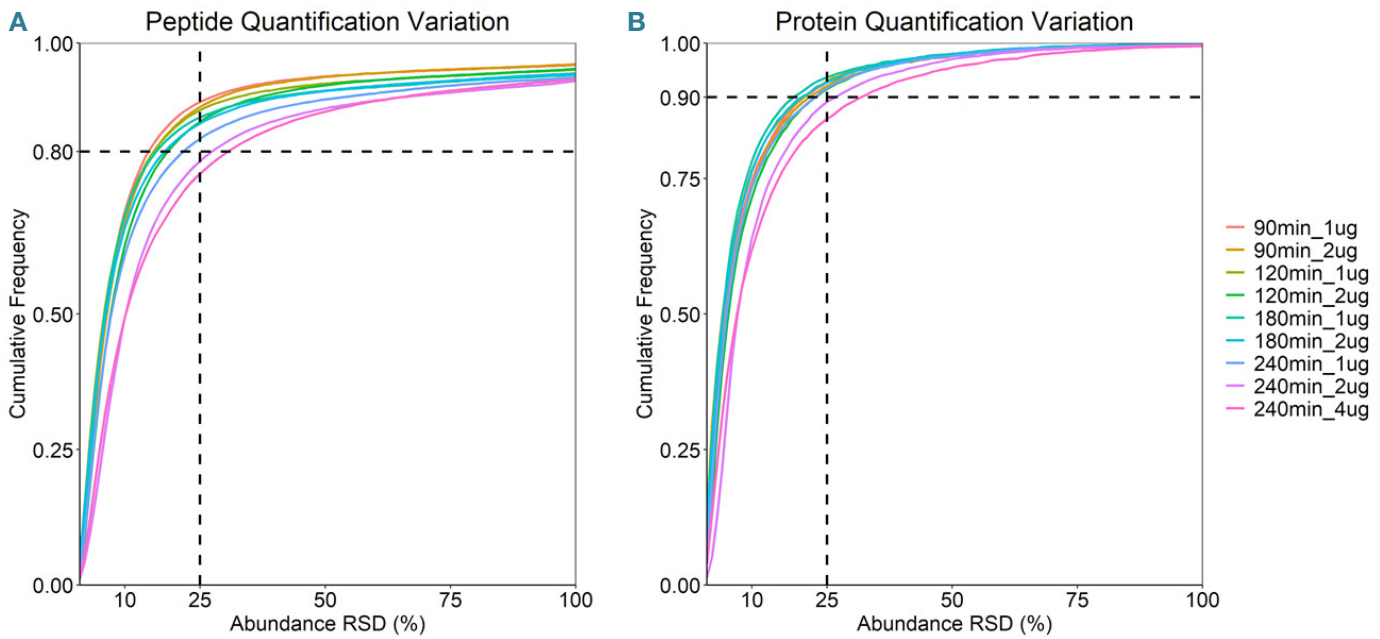

Figure 8. The cumulative frequency of peptides (A) and proteins (B) that were quantified with the specified level of variation measured as RSD, %. Around 80% of peptides and 90% proteins are quantified with RSD <25% over the different gradients and sample amount.

### Reproducibility of EASY-Spray PepMap Neo columns for shotgun proteomics

The reproducibility of results obtained with multiple columns is essential for the analysis of large sample cohorts. It is also critical for continuous quality control of results and for monitoring of the system performance over time. The higher packing pressure conditions adopted for PepMap Neo columns permits reproducible elution profiles for complex peptide digests over multiple columns, thus affording a high level of data reproducibility. We evaluated the column impact on HeLa proteome coverage under identical analysis

conditions. The four 75  $\mu$ m I.D.  $\times$  75 cm columns were used for HeLa proteome profiling with a 4-hour gradient (240 min). The column-to-column variation for peptide and protein identifications was below 5% and 1%, respectively (Figure 9). Similar results were obtained with the number of peptides and proteins that can be quantified in each sample (Figure 9). Thus, considering the reproducible performance on LC and MS hardware PepMap Neo columns showed excellent column-to-column reproducibility even for very long gradients and operation at a maximum pressure of 1500 bar during sample loading and fast column equilibration.

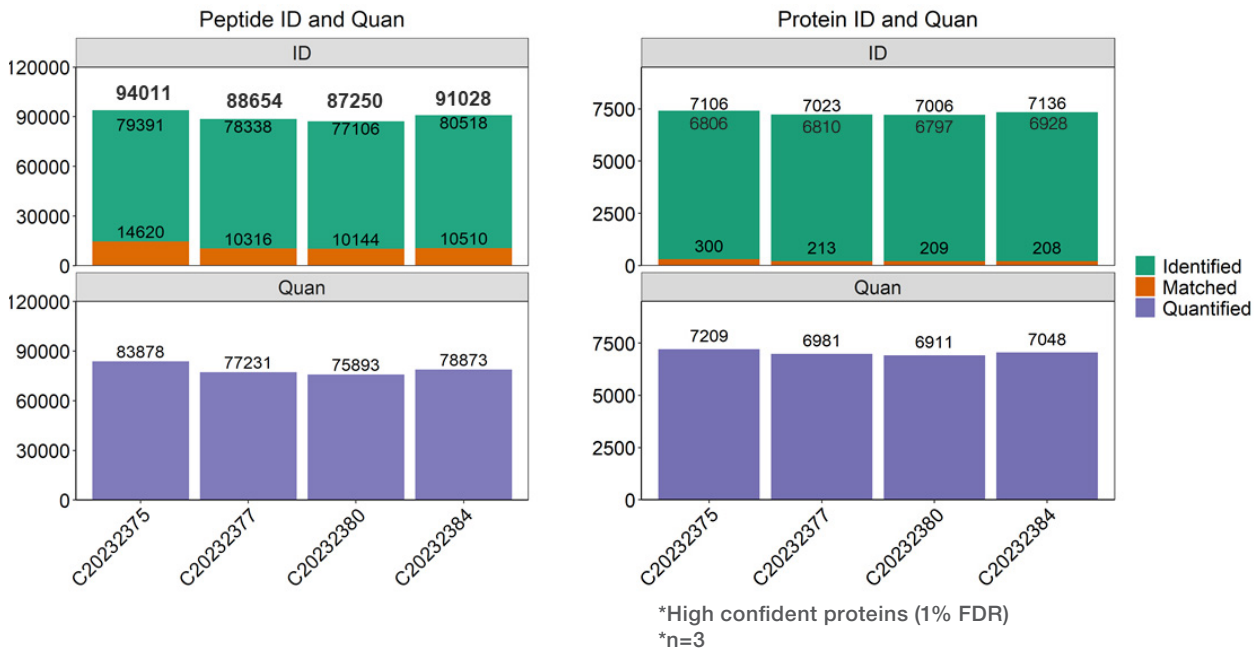

Figure 9. Reproducible identification and quantification of HeLa peptides and proteins over 4 EASY-Spray PepMap Neo columns while using Vanquish Neo UHPLC system coupled with the Orbitrap Exploris 480 mass spectrometer.



## Vanquish Neo system flow rate versatility for maximizing MS sensitivity

The wide flow-pressure footprint and reproducible gradient delivery of the Vanquish Neo system permits the study of the influence of changing flow rates on ESI-MS sensitivity as well as upon overall LCMS performance in bottom-up proteomics experiments. The backpressure capabilities of the system make it possible to deliver flow rates of up to 500 nL/min on 75cm long columns where the pressure reaches 1450 bar during the separation and 1500 bar during sample loading and column equilibration (Figure 10).

The improved ionization efficiency in ESI-MS afforded by the lower flow rates results in up to a 40% sensitivity gain (peak height) (Figure 11A). The increase in MS1 intensity, however, had no significant impact on either the number of MS/MS events, or the number of peptide-spectrum matches (PSMs), or peptide, and protein identifications (Figure 11B). This suggests that the MS1 intensity levels required for the maximum possible protein coverage were already met at the elevated nano-flow rates thanks to the high sensitivity of Orbitrap Exploris 480 mass spectrometer under the separation conditions employed in these experiments. This in turn implies a level of flexibility afforded by the nanoLCMS system for adjusting flow rates to achieve the same proteomic analysis depth for smaller sample loads.

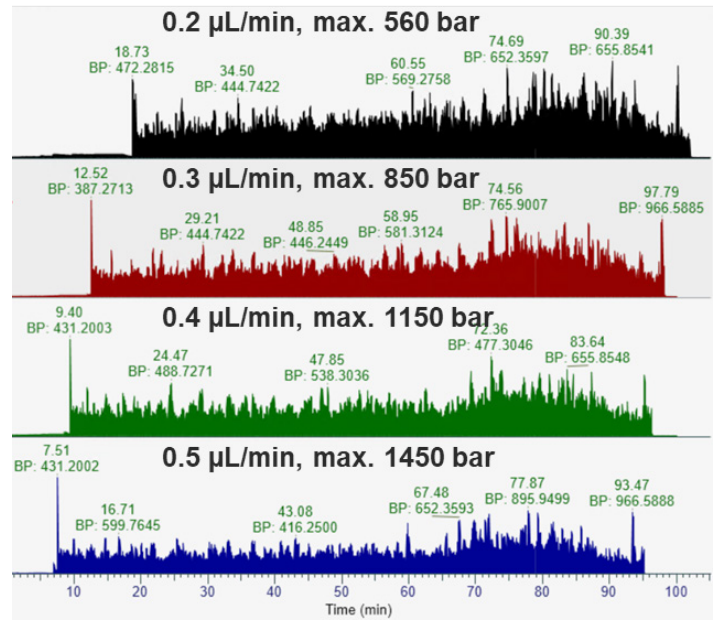

Figure 10. The typical nanoLCMS profiles for HeLa protein digest separated on 75 μm I.D. x 75 cm column with flow rates from 200 to 500 nL/min and pressure during the gradient separation from 560 to 1450 bar

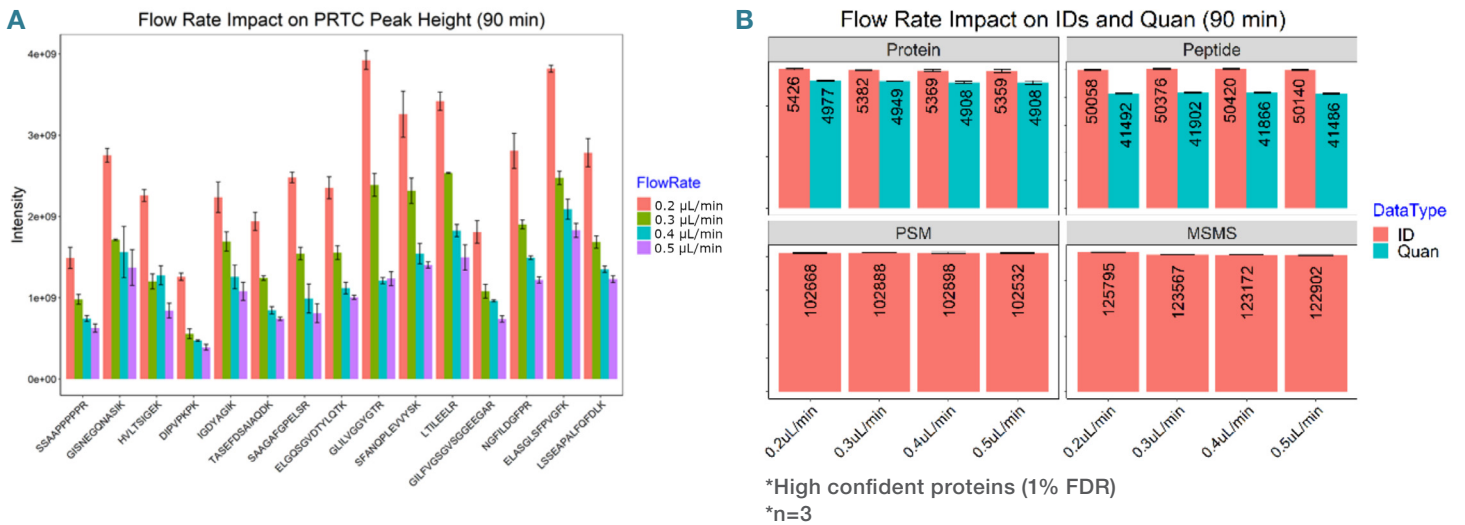

Figure 11. The effect of flow rate from 0.2 to 0.5 μL/min on the PRTC peak height (A) and collected MS/MS events, the number of identified PSMs, identified and quantified peptides and proteins with 90-min gradient and 1 μg of HeLa protein digest (B).

## Column coupling to achieve maximum separation performance

The high separation performance capabilities of the 75  $\mu\text{m}$  I.D.  $\times$  75 cm EASY-Spray PepMap Neo column together with the flow-pressure capabilities of the Vanquish Neo system pave the way to new levels in separation performance through column coupling. Proof-of-principle experiments were conducted by coupling a novel double nanoViper PepMap Neo 75  $\mu\text{m}$  I.D.  $\times$  75 cm column with an EASY-Spray PepMap Neo column with the same dimensions. The coupling of the new double nanoViper column and EASY-Spray column was readily achieved using a standard nanoViper union (Figure 12).

The first column was placed into a thermostatted column compartment maintained at 60  $^{\circ}\text{C}$  and the temperature of the EASY-Spray PepMap Neo column was maintained at 50  $^{\circ}\text{C}$ . The temperature difference permitted additional sample re-focusing before the separation on the 2nd column (Figure 12). The 1.5 m combined column generates 1350 bar back pressure during the separation gradient. We observed ca. 3 seconds FWHM improvement with 1.5 m column compared to 75 cm long column for the 240-min gradient which opens new possibilities for deep single-shot proteomics.

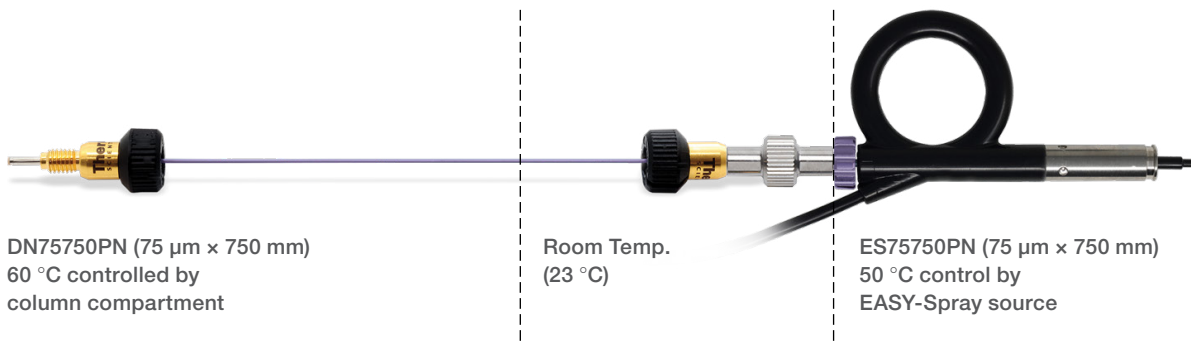

Figure 12 Coupling a double nanoViper PepMap Neo 75  $\mu\text{m}$  I.D.  $\times$  75 cm column and EASY-Spray PepMap Neo column to create a 75  $\mu\text{m}$  I.D. column with 150 cm total length.

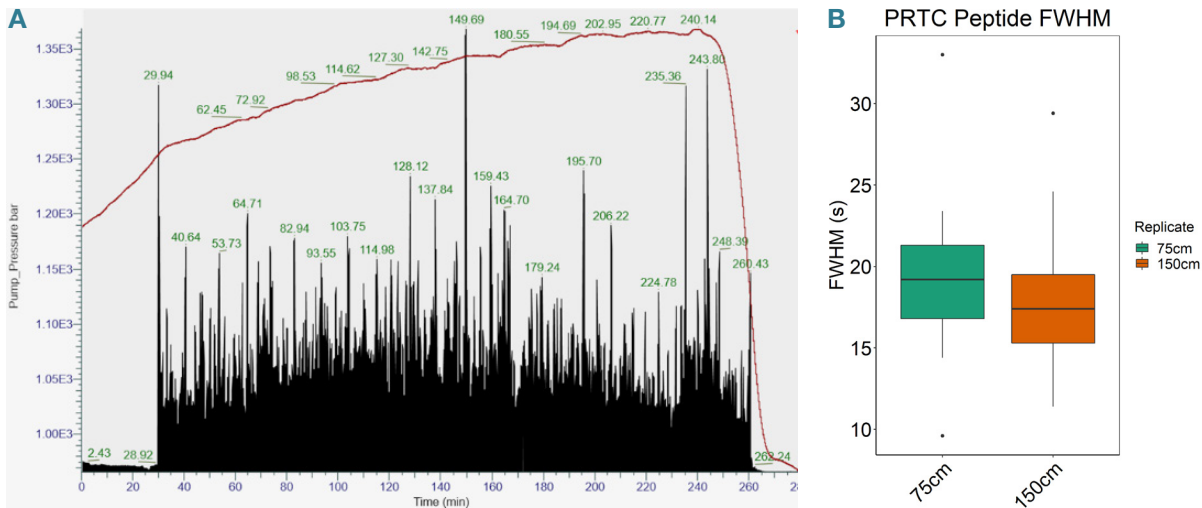

Figure 13. The chromatographic separation of 2  $\mu\text{g}$  HeLa digest with a 240-min gradient at 0.25  $\mu\text{L}/\text{min}$  generating a back pressure of 1350 bar (A); Excellent peak width across the LC gradient (B).

## Conclusions

Deep dive proteomics research employing nanoLCMS based analytical systems continues to play a pivotal role in deep-dive discovery proteomics. Here we evaluated the performance of the Vanquish Neo UHPLC system coupled with an Orbitrap Exploris 480 mass spectrometer for bottom-up proteome profiling. The Vanquish Neo boosts chromatographic performance while employing long columns and long gradients, permits maximal MS utilization even for direct injection workflows, and provides versatility to separate peptides at low or elevated flow rates to optimize ESI-MS sensitivity. Furthermore its ultra-high pressure capacity creates flexibility to explore the separation power of ultra-long columns. The EASY-Spray and double nanoViper PepMap Neo columns show excellent reproducibility of results for repeated analysis on the same column as well as between columns. The double nanoViper column format also allows easy column-to-column coupling for maximum separation performance. Here we demonstrate improved peptide and protein identification in single-shot proteomics along with enhanced robust system operation for continuous data generation. Taken together, the next-generation Vanquish Neo UHPLC system combined with the latest PepMap Neo columns and Orbitrap based HRAM Mass Spectrometers continue to drive nanoLCMS based bottom-up proteomics research to the next level.

## References

1. Schwenk, J. M. et al. The Human Plasma Proteome draft of 2017: building on the Human Plasma Peptide Atlas from mass spectrometry and complementary assays. *J. Proteome Res.* 16, 4299–4310 (2017).
2. Cox, J.; Mann, M. Quantitative, high-resolution proteomics for data-driven systems biology. *Annu Rev Biochem.* 2011, 80, 273-99.
3. Köcher, T. et al. Development and performance evaluation of an ultralow flow nano liquid chromatography-tandem mass spectrometry set-up. *Proteomics.* 2014, 14(17-18), 1999-2007
4. Wang, X. et al. Peak capacity optimization of peptide separations in reversed-phase gradient elution chromatography. *Anal. Chem.* 2009, 78 (10), 3406-3416.
5. Lopez-Ferrer, D. et al. Pushing the limits of bottom-up proteomics with state-of-the-art capillary UHPLC and Orbitrap mass spectrometry for reproducible quantitation of proteomes. Thermo Fisher Scientific Application Note AN639, 2016.
6. Wilm, M. and Mann, M. Analytical properties of the nano electrospray ionization source. *Anal. Chem.* 1996, 68, 1, 1-8.
7. Köcher, T. et al. Ultra-High-Pressure RPLC Hyphenated to an LTQ-Orbitrap Velos Reveals a Linear Relation between Peak Capacity and Number of Identified Peptides. *Anal. Chem.* 2011, 83 (7), 2699-2704.
8. Jon Ferguson, et al. A novel 75 cm column size gives increased resolution and better sequence coverage. Thermo Fisher Scientific Application Note AN21550, 2019.

 Learn more at [thermofisher.com/vanquishneo](https://thermofisher.com/vanquishneo)